

JVC

DLA-RS520

D-ILA Custom Install
Home Theater Projector

REFERENCE SERIES

4K e-shift4



The DLA-RS520 is a high performance, fully-customizable home theater projector that produces exquisite quality images with class leading 130,000:1 native contrast ratio. This THX 3D and ISF certified projector accepts native 4K 60P (4:4:4) material through Full Speed 18Gbps HDMI/HDCP 2.2 compatible inputs and displays it with stunning 3840 x 2160 precision.

- 1900 Lumens with High Power Lamp (PK-L2615U)
- 130,000:1 Native Contrast Ratio
- Three 1920 x 1080 0.7-inch D-ILA devices
- e-shift4 4K Precision 3840 x 2160 Projected Image
- Two 18Gbps HDMI/HDCP 2.2 Compatible Inputs
- THX® 3D Certified
- ISF (Imaging Science Foundation) Licensed
- Improved Multi Pixel Control (MPC) w/Auto Mode MPC works with 4K60P (up to 4:4:4) signals
- Low Latency Mode reduces gaming/PC frame delays
- New Auto HDR (w/HDR10 signal) plus Hybrid Log-Gamma
- Motion Enhance (2D, 3D, 4K) w/Upgraded CMD
- Digital Cinema Initiative (DCI) Color Space
- 1.4:1 to 2.8:1 motorized zoom lens w/Horizontal and Vertical offset
- Lens memory function memorizes 10 positions for focus, zoom and shift
- Control: Control4 SDDP / LAN / RS-232C / IR / 12V Screen Trigger Output / 3D Sync Output
- 3 Year Warranty

Note: Optional Active 3D Glasses (PK-AG3) and RF Emitter (PK-EM2) are required for viewing images in 3D.



D-ILA JVC's 6th Generation D-ILA Imaging Device
 The exceptional picture quality achieved by JVC projectors is a result of the precision technology behind the D-ILA device which features a 0.3μ pixel gap and high light efficiency for bright, high native contrast and superior detail.

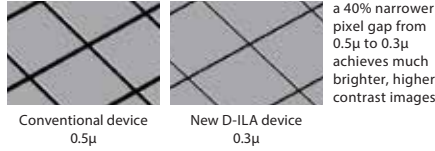

4K e-shift4 4K Precision JVC e-shift4 Technology

The 4th generation of e-shift provides optimization for signals up to 4K, new Multiple Pixel Control features AUTO input mode detection for convenience and adds signal compatibility extending to 4K60P (up to 4:4:4). A new processing algorithm improves sharpness for an advanced 4K picture.



HDR10 plus Hybrid Log-Gamma

HDR content such as UHD Blu-ray discs incorporate extended dynamic range, 10bit color and wide BT.2020 color gamut. This demands exceptional specifications and exacting performance from display devices. DLA-RS520 supports BT.709 and Digital Cinema Initiative (DCI) color gamut with BT.2020 color mapping, with high native contrast and bright vivid images to let you experience a full complement of HDR content.

Hybrid Log-Gamma is an additional HDR Gamma mode that is used for live broadcast or streaming events.



External Dimensions (unit: inches | mm)

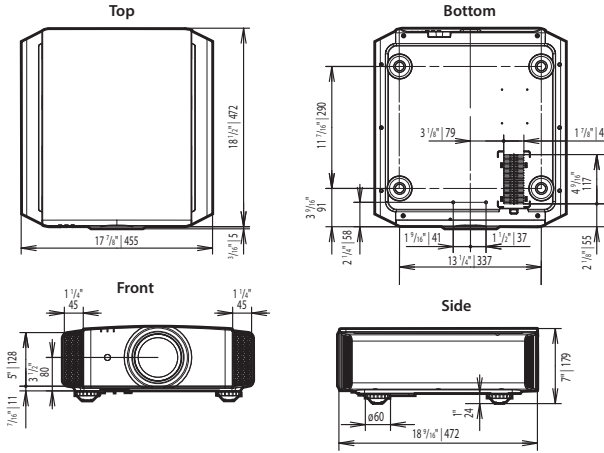

Notes about viewing 3D video content

- The optional 3D Synchro Emitter and 3D glasses are required to view 3D images from the D-ILA projectors. 3D video software (3D media or output of 3D broadcasts) and a 3D-compatible video player are also required.
- Perception of 3D images will vary with individual viewers.
- Stop viewing 3D images immediately if any discomfort such as headaches, dizziness, eye fatigue, etc. occurs.
- Viewing of 3D images by children under the age of five is not recommended.
- Read the Safety Precautions in the User Manual carefully before viewing any 3D source.

The projector is equipped with a new super-high pressure mercury lamp, which may break, emitting a loud noise, when it is subjected to shock or after it has been used for some length of time. Please note that, depending on how the projector is used, there can be considerable difference between individual lamps regarding how many hours they will operate before requiring replacement. An additional payment is required for installation of a new lamp, if necessary. The projector lamp requires periodic replacement and is not covered by the projector's warranty. The lamp warranty is one year or 1000 hours, whichever comes first. Please be aware that, because the D-ILA device is manufactured using highly advanced technologies, 0.01% or fewer of the pixels may be non-performing (always on or off). Design and specifications are subject to change without notice. All pictures on this brochure are simulated. Adobe is a trademark or registered trademark of Adobe Systems Incorporated in the U.S. and/or other countries. HDMI, the HDMI logo and High-Definition Multimedia Interface are registered trademarks of HDMI Licensing LLC. All other brand or product names may be trademarks and/or registered trademarks of their respective owners. Any rights not expressly granted herein are reserved.

Copyright © 2016, JVCKENWOOD Corporation. All Rights Reserved.

18Gbps Full Speed HDMI Inputs with HDCP2.2

With the current expansion of 4K streaming and the next generation Ultra HD Blu-ray, JVC has incorporated the latest HDMI/HDCP2.2 standard on both DLA-RS520 HDMI inputs allowing two HDCP2.2 copy protected devices to be connected at the same time up to 60 fps.

Superior Color Performance and Contrast — Improved Optical Engine Design

In order to take full advantage of UHD Blu-ray and HDR the optical engine incorporates advanced color filtering which enables a wider color gamut. The viewing experience comes alive with the vivid color saturation and extended contrast range found in these new formats. Extended color gamut enables a larger color palette to more faithfully reproduce the intent of the content creator in movies, sporting events or photography. A variety of color modes are available and can be setup as custom user memories.

Control4 Home Automation

All JVC Reference Series projectors are Control4 SDDP (Simple Device Discovery Protocol) software certified so they can easily be integrated into a Control4 home automation system.

Optional Equipment

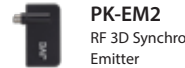

Connectors



Specifications

		DLA-RS520
Imaging device		0.7 inch Full HD D-ILA (1920 x 1080) x3
4K e-shift4 Technology		Yes
Resolution		3840 x 2160 Precision via e-shift4 technology (1920 x 1080 in 3D mode)
Lens		2X Motorized Zoom & Focus, (f2)1.4 to 2.8 (f4) Throw Distance Range Throw distance=Screen width X1.4 (Min.), Screen width X2.8 (Max.)
Lens Shift		Motorized Shift±80% Vertical and ±34% Horizontal
Light Source		NSH 265W Lamp (lamp life: approx. 4500 hours when the lamp is in Low mode)
Contrast Ratio		Native: 130,000:1 Dynamic: 1,300,000:1
Input Terminals	HDMI	2 (Full Speed 18Gbps HDMI/HDCP 2.2 Compatible w/HDR)
Output Terminals	3D Sync	1 (Mini DIN 3pin)
	Trigger	1 (Mini jack, DC12V/100mA)
Control Terminals	RS-232C	1 (D-sub 9pin)
	LAN (RJ-45)	1
Digital Video Signal		480p, 576p, 720p/50 Hz, 720p/60 Hz, 1080i/50 Hz, 1080i/60 Hz, 1080p/24 Hz, 1080p/50 Hz, 1080p/60 Hz, 3840x2160/24Hz, 3840x2160/25Hz, 3840x2160/30Hz, 3840x2160/50Hz*, 3840x2160/60Hz** 4096x2160/24Hz*, 4096x2160/25Hz*, 4096x2160/30Hz*, 4096x2160/50Hz*, 4096x2160/60Hz**
3D Signal	Frame Packing	720p/50 Hz, 720p/60 Hz, 1080p/24 Hz
	Side-by-Side	1080i/60 Hz, 1080p/60 Hz, 1080i/50 Hz, 1080p/50 Hz, 1080p/24 Hz, 720p/50 Hz, 720p/60 Hz
	Top-and-Bottom	720p/50 Hz, 720p/60 Hz, 1080p/24 Hz
PC Input Signal Format	HDMI	VGA 60, VGA 59.94, SVGA 60, XGA 60, WXGA 60, WXGA+ 60, SXGA 60, WSXGA+ 60, WUXGA 60
Dimensions	(WxHxD-inches)	17 7/8 x 7 x 18 9/16
Weight (net)	(lbs)	34.4

*1 When the color space is RGB/YCbCr(4:4:4), only 8-bit input is supported.

** 4096x2160 Signal will be cropped equally on left and right side and image will be displayed 3840x2160.