

D-ILA[®] Projector

DLA-RS49

DLA-RS4910

DLARS57

DLA-RS67/RS6710

RS232 Command

Communication Specification

Ver. 1.31RS

2014/2/28

JVCKENWOOD Corp.
Projector Division

(*D-ILA is the trademark of JVCKENWOOD Corp.

Document No. PJ005030305B

CONTENTS

1 OUTLINE	4	4.7.2 Reference	22
2 INTERFACE	4	4.8 Source Asking [Source].....	23
2.1 Terminal	4	4.8.1 Reference	23
2.2 External Controller Connector	4	4.9 Model status asking [Model].....	24
2.3 Communication Line	4	4.9.1 Reference	24
3 PROTOCOL	5	4.10 Adjustment [AdjustmentCommand]	25
3.1 Communication specification.....	5	4.10.1 Special data	30
3.2 Data format	5	4.10.2 Special2 Data	39
3.3 Header table	5	4.10.3 Special3 Data	39
3.4 Unit ID table	6	4.10.4 Special9 Data	40
3.5 Command table.....	6	4.10.5 Special10 Data	40
3.6 Parameter	7	4.10.6 Special14 Data	40
3.6.1 Numeric value parameters	7	4.10.7 Operation	41
3.6.2 Special parameter.....	7	4.10.8 Reference	42
3.7 Exit code	8	LAN setup [Lan Setup]	45
3.8 Error handling	8	4.10.9 Operation	46
3.9 Communication sequence.....	9	4.10.10 Reference.....	47
4 COMMAND CONTROL.....	10		
4.1 NULL command	10		
4.1.1 Operation	10		
4.1.2 Reference	10		
4.2 Power [Power].....	11		
4.2.1 Operation	11		
4.2.2 Reference	12		
4.3 Input [Input].....	13		
4.3.1 Operation	14		
4.3.2 Reference	14		
4.4 Remote control pass-through [RemoteCode]15			
4.4.1 Operation	16		
4.5 Setup [Setup].....	17		
4.5.1 Operation	18		
4.6 Gamma data of Gamma table "Custom 1/2/3" [GammaRed, Green, Blue]	19		
4.6.1 Operation	20		
4.6.2 Reference	20		
4.7 Panel Alignment (zone) Data [Panel Alignment(Zone) Red, Blue]	20		
4.7.1 Operation	22		

Table Number

Table 4-1	NULL CMD	10	Table 4-40	ASPECT CMD DATA	34
Table 4-2	POWER CMD.....	11	Table 4-41	MASK CMD DATA	35
Table 4-3	POWER CMD DATA.....	11	Table 4-42	3D CONVERSION CMD DATA	35
Table 4-4	POWER CMD STATUS	11	Table 4-43	LENS CONTROL (Focus / Zoom / Shift) CMD DATA	35
Table 4-5	INPUT CMD	13	Table 4-44	LENS COVER CMD DATA	35
Table 4-6	INPUT CMD DATA.....	13	Table 4-45	Above CMD DATA	35
Table 4-7	REMO CMD	15	Table 4-46	INSTALLATION STYLE CMD DATA	35
Table 4-8	REMO CMD DATA.....	15	Table 4-47	ANAMORPHIC CMD DATA	35
Table 4-9	SETUP CMD	17	Table 4-48	PANEL ALIGNMENT CMD DATA	36
Table 4-10	SETUP CMD SUB.....	17	Table 4-49	SCREEN SIZE CMD DATA	36
Table 4-11	GAMMA DATA CMD.....	19	Table 4-50	HIGH ALTITUDE CMD DATA.....	36
Table 4-12	PANEL ALIGNMENT(ZONE) DATA CMD	21	Table 4-51	VIEWING DISTANCE CMD DATA	36
Table 4-13	SOURCE CMD.....	23	Table 4-52	WALL COLOR CMD DATA.....	36
Table 4-14	SOURCE CMD DATA.....	23	Table 4-53	LENS MEMORY SAVE CMD DATA	37
Table 4-15	MODEL STATUS CMD.....	24	Table 4-54	BACK COLOR CMD DATA.....	37
Table 4-16	MODEL STATUS CMD DATA	24	Table 4-55	MENU POSITION CMD DATA.....	37
Table 4-17	ADJUSTMENT CMD.....	25	Table 4-56	Source Display, Logo CMD DATA	37
Table 4-18	ADJUSTMENT CMD SUB	25	Table 4-57	LANGUAGE CMD DATA	38
Table 4-21	PICTURE MODE CMD DATA.....	30	Table 4-58	TRIGGER CMD DATA	38
Table 4-22	CLEAR BLACK CMD DATA	30	Table 4-59	OFF TIMER CMD DATA	38
Table 4-23	INTELLIGENT LENS APERTURE CMD DATA.....	30	Table 4-60	ECO MODE CMD DATA.....	38
Table 4-24	COLOR PROFILE CMD DATA.....	31	Table 4-61	INPUT CMD DATA.....	38
Table 4-25	COLOR TEMP TABLE CMD DATA	31	Table 4-62	SOURCE CMD DATA	39
Table 4-26	COLOR TEMP CORRECTION CMD DATA	32	Table 4-63	DEEP COLOR CMD DATA.....	39
Table 4-27	GAMMA CMD DATA.....	32	Table 4-64	COLOR SPACE CMD DATA	39
Table 4-28	GAMMA CORRECTION CMD DATA	32	Table 4-67	LENS MEMORY SAVE CMD DATA < operation>	40
Table 4-29	COLOR MANAGEMENT CMD DATA.....	33	Table 4-68	LENS MEMORY SAVE CMD DATA < Reference>	40
Table 4-30	CMS DISPLAY COLOR CMD DATA	33	Table 4-69	LAN SETUP CMD	45
Table 4-31	CLEAR MOTION DRIVE CMD DATA.....	33	Table 4-70	LAN SETUP CMD SUB.....	45
Table 4-32	LAMP POWER CMD DATA	33	Table 4-71	DHCP Client	45
Table 4-33	MPC ANALYZE CMD DATA	33	Table 4-72	NETWORK RESTART	45
Table 4-34	4K e-shift CMD DATA	33			
Table 4-35	HDMI INPUT LEVEL CMD DATA.....	34			
Table 4-36	HDMI COLOR SPACE CMD DATA	34			
Table 4-37	HDMI CEC CMD DATA.....	34			
Table 4-38	HDMI 2D/3D CMD DATA	34			
Table 4-39	HDMI 3D Phase CMD DATA	34			

1 Outline

This specification describes how to control the D-ILA projector * by using an external controller through the RS-232C interface.

* DLA-X500R/XC5880R/RS49, DLA-RS4910, DLA-X700R/X7880R/RS57 and DLA-X900R/RS67,RS6710Interface

2 Interface

2.1 Terminal

D-SUB 9pin Male terminal

Pin No.	Name	Pin No.	Name
1	NC	6	NC
2	RXD	7	NC
3	TXD	8	NC
4	NC	9	NC
5	GND		

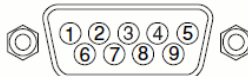

2.2 External Controller Connector

Serial port connector (RS-232C)

For type of the connector and pin layout, please refer to each controller's specifications.

2.3 Communication Line

This control system uses RXD (receive data), TXD(transmit data) and GND line. Use an RS-232C crossover cable to connect the projector to the external controller like as PC.

3 Protocol

3.1 Communication specification

Communication System	Asynchronous
Interface	RS-232C
Baud rate	19200 bps
Data length	8 bits
Parity	None
Stop bit	1 bit
Flow control	None
Communication code	ASCII character code

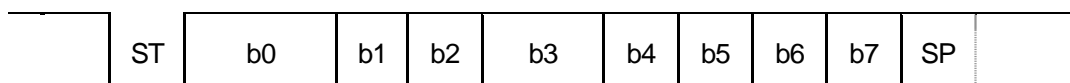

3.2 Data format

Control commands consist of Header, Unit ID, Command, Data and End. (Refer to the below)

*The length of the control command varies according to function.

1 byte	2 bytes		2 bytes		n+1 bytes			1 byte
Header	Unit ID		Command		Data[0]	...	Data[n]	End

Header: Indicates the start of communication (see paragraph 3.3, Header table).

Unit ID: Specifies the device to be controlled.

Command: See paragraph 3.5, Command table.

Data [i]: Parameter corresponding to the command (data i = 0, 1, .., n).

End: Indicates the end of communication.

3.3 Header table

Added header varies according to type of control command.

HEX	ASCII	Type
0x21	'!'	Operation command
0x3F	'?'	Reference command
0x40	'@'	Response command
0x06	ACK	ACK

Operation command: Added when there is an operation command notification.

Reference command: Added when there is a reference command notification.

Response command: Added when there is a response command notice in response to a reference.

ACK: ACK response is given if the command reception is normal.

3.4 Unit ID table

- ♦ The unit ID consists of two bytes, the unit code and the individual code.
- ♦ The unit code is 0x89(Fixed)
- ♦ The individual code signifies "projector ID" and it is fixed on 0x01.
- ♦ A changed individual code is preserved on the unit side.

Unit code							
b7	b6	b5	b4	b3	b2	b1	b0
1	0	0	0	1	0	0	1

Individual code							
b7	b6	b5	b4	b3	b2	b1	b0
0	0	0	0	0	0	0	1

3.5 Command table

The command consists of two bytes of ASCII characters.

HEX		ASCII		Function	Operation	Reference
0x00,	0x00	NUL	NUL	NULL command	✓	-
0x50,	0x57	'P'	'W'	Power [PoWer]	✓	✓
0x49,	0x50	'I'	'P'	Input [InPut]	✓	✓
0x52,	0x43	'R'	'C'	Remote control code through [Remote Code]	✓	-
0x53,	0X55	'S'	'U'	Initial setup [SetUp]	✓	✓
0x47,	0x54	'G'	'T'	Gamma table switch [Gamma Table]	✓	✓
0x47,	0x53	'G'	'S'	Gamma bank switch [Gamma-bank Switch]	✓	✓
0x47,	0x50	'G'	'P'	Gamma coefficient of the Gamma table "Custom 1/2/3" [Gamma Power]	✓	✓
0x47,	0x52	'G'	'R'	Gamma data (Red) of the Gamma table "Custom 1/2/3" [Gamma Red]	✓	✓
0x47,	0x47	'G'	'G'	Gamma data (Green) of the Gamma table "Custom 1/2/3" [Gamma Green]	✓	✓
0x47,	0x42	'G'	'B'	Gamma data (Blue) of the Gamma table "Custom 1/2/3" [Gamma Blue] 'R'	✓	✓
0x50,	0x52	'P'		Red of Panel Alignment (zone)	✓	✓
0x50,	0x42	'P'	'B'	Blue of Panel Alignment (zone)	✓	✓
0x53,	0x43	'S'	'C'	Source asking [SourCe]	-	✓
0x4D,	0x44	'M'	'D'	Model status asking [MoDel]	-	✓
0x50,	0x4D	'P'	'M'	Picture adjustment [adjustment of Picture] : Picture Adjust	✓	✓
0x49,	0x53	'I'	'S'	Picture adjustment [adjustment of Picture] : Input Signal	✓	✓
0x49,	0x4E	'I'	'N'	Picture adjustment [adjustment of Picture] : Installation	✓	✓
0x44,	0x53	'D'	'S'	Picture adjustment [adjustment of Picture] : Display Setup	✓	✓
0x46,	0X55	'F'	'U'	Picture adjustment [adjustment of Picture] : Function	✓	✓
0x49,	0x46	'I'	'F'	Picture adjustment [adjustment of Picture] : Information	-	✓
0x4C	0x53	'L'	'S'	LAN setup [Lan Setup]	✓	✓

3.6 Parameter

3.6.1 Numeric value parameters

Signed 2-byte hexadecimal code represented by 4 (byte) characters.

Ex-1)

The parameter indication '20' (decimal):

Since '20' (decimal) is represented as '0014' in signed 2-byte hexadecimal, its parameter is:

'0014'(30H 30H 31H 34H)

Ex-2)

The parameter to indicate '-2' (decimal):

Since '-2' (decimal) is represented as 'FFFE' in signed 2-byte hexadecimal, its parameter is:

'FFFE'(46H 46H 46H 45H)

3.6.2 Special parameter

The parameters are generally interpreted with ASCII characters.

But some of the commands have a unique interpretation (for the details, see the section on Command sequences).

HEX	ASCII	Meaning
0x2B	'+'	'+'
0x2D	'_'	'_'
0x30	'0'	OFF/NO/Disable
0x31	'1'	ON/YES/Enable
0x30 ~ 0x39	'0'~'9'	'0'~'9'
0x41 ~ 0x5A	'A'~'Z'	'A'~'Z'

3.7 Exit code

0x0A(LineFeed) fixed.

3.8 Error handling

- ♦ An external controller should not transmit the next commands until it receives an ACK that the transmitted unit ID and the command match.
- ♦ The specifications for timeout and retry when an ACK response has not been received are not specified here; the specifications unique to the external controller may be used.
- ♦ If the byte interval is blank for 50 ms or longer, initialize the transmit-receive sequence (the received data is discarded).
- ♦ If a unit ID other than its own is received, it is ignored.
- ♦ If the unit ID matches but an undefined header/command is received, it is ignored.
- ♦ If the header/command is normal but an undefined parameter is received, it is ignored.
- ♦ Even if the command receipt is normal (ACK response) and the parameter is valid, it may be ignored, depending on the state of the projector. For the details, see the instruction manual for the projector (for example, projector, power ON operation in the power cooling state, etc.).

3.9 Communication sequence

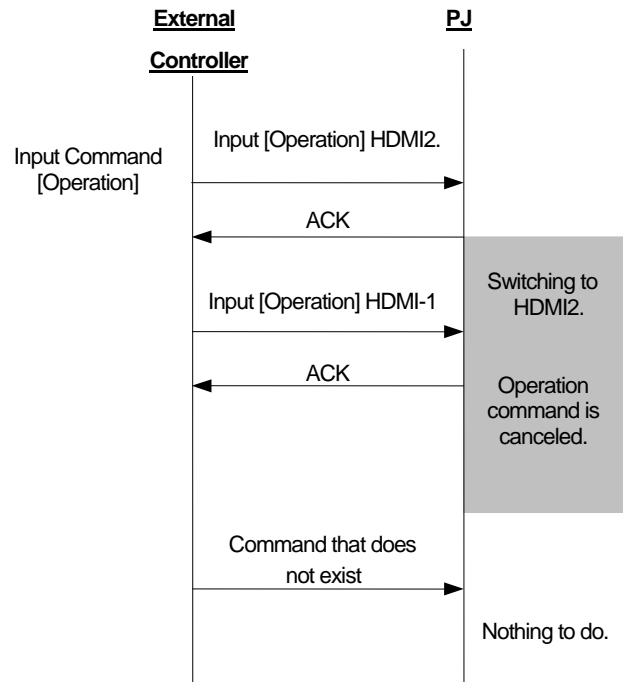

[ACK/NACK concept]

When the projector receives a command, it returns ACK immediately if the command is prescribed. If not, the projector returns nothing.

[Operation sequence]

When projector receives an operation command, it returns ACK immediately and performs the command operation. However, if the projector receives the command while user operation is going on, it only returns ACK for the command but operation is canceled.

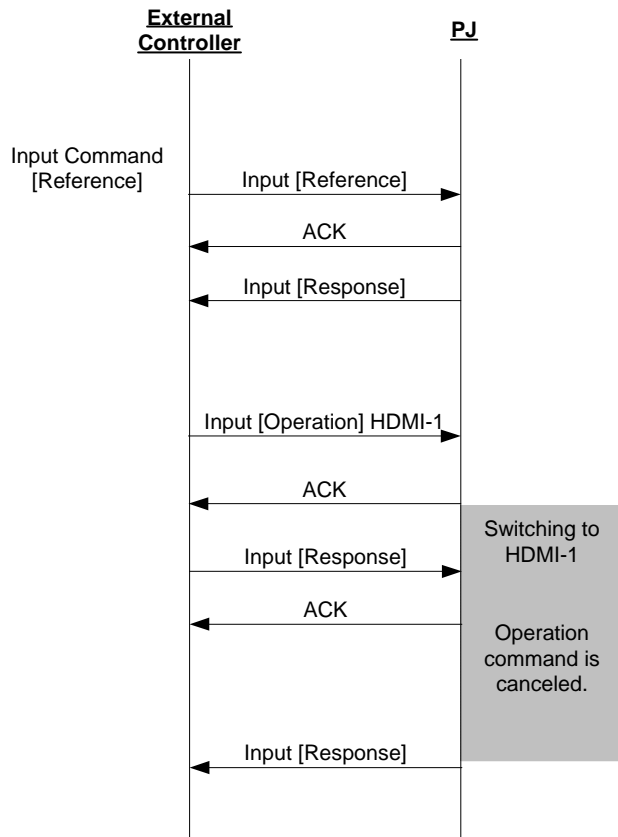

[Reference sequence]

When projector receives a reference command, it returns ACK immediately, and then transmits related information for command as response to external controller.

If the projector receives a reference command while in user operation, it transmits ACK immediately, and then it transmits response command after the completion of user operation.

This is because of conflict between projector information and the information passed to external controller via response command based on timing, if the reference command is approved while in user operation.

4 Command control

4.1 NULL command

In using CEDIA commands, it is used in order to confirm whether transmission is possible.

It is used to confirm whether the external controller and the projector are properly connected.

Command code

Table 4-1 NULL CMD

HEX		ASCII		Function	Operation	Reference
0x00	0x00	NULL	NULL	NULL command	✓	-

Parameter

None

4.1.1 Operation

Use the command as shown in the following examples.

Purpose: To confirm whether the external controller and the projector are properly connected.

(1) Data is transmitted from the external controller to the projector as follows.

1: External controller →					
0x21	0x89	0x01	0x00	0x00	0x0A
!(Operation)	PJ	Individual:1	NULL	NULL	End

(2) If the external controller and the projector are connected and the projector is operating normally, the projector returns an ACK to the external controller as a NULL command response.

2: ← Projector					
0x06	0x89	0x01	0x00	0x00	0x0A
ACK	PJ	Individual : 1	NULL	NULL	End

By the above exchange, it can be confirmed whether the connection and communication are normal or abnormal.

4.1.2 Reference

N/A

4.2 Power [PoWer]

Used for power ON/OFF operation and for referencing the power setting state of the projector.

Command code

Table 4-2 POWER CMD

HEX		ASCII		Function	Operation	Reference
0x50	0x57	'P'	'W'	Power [POWER]	✓	✓

Parameters

Table 4-3 POWER CMD DATA

HEX	ASCII	Operation
0x30	'0'	Power OFF
0x31	'1'	Power ON

【Data 0】

Table 4-4 POWER CMD STATUS

HEX	ASCII	Operation
0x30	'0'	Standby
0x31	'1'	Lamp On
0x32	'2'	Cooling
0x33	'3'	Reserved
0x34	'4'	Error

4.2.1 Operation

Use the command as shown in the following examples.

Purpose: To turn the Projector's power OFF. (Current state: Power-ON)

(1) Data is transmitted from the external controller to the Projector as follows.

1: External controller →						
0x21	0x89	0x01	0x50	0x57	0x30	0x0A
'!(Operation)	PJ	Individual : 1	'P'	'W'	OFF	End

(2) If the projector receives data (1) and the command reception is normal, the projector returns an ACK as follows.

2: ← Projector					
0x06	0x89	0x01	0x50	0x57	0x0A
ACK	PJ	Individual : 1	'P'	'W'	End

(3) The projector turns power OFF.

The power can be turned OFF by the above exchange.

- The power-OFF operation can be done by a sequence similar to that for power-ON.
- The projector ignores data in the same state. For example, even if power-ON data is sent with the projector in power-ON mode, no projector operation is done.

4.2.2 Reference

Use the command as shown in the following examples.

Purpose: To confirm the present projector's power state. (Current state: Power-ON)

- (1) Data is transmitted from the external controller to the projector as follows.

1: External controller →					
0x3F	0x89	0x01	0x50	0x57	0x0A
'?' (Reference)	PJ	Individual : 1	'P'	'W'	End

- (2) If the projector receives data (1) above and the command reception was normal, the projector returns an ACK as follows.

2: ← Projector					
0x06	0x89	0x01	0x50	0x57	0x0A
ACK	PJ	Individual : 1	'P'	'W'	End

- (3) Next, the projector transmits a report of the power setting to the external controller.

3: ← Projector						
0x40	0x89	0x01	0x50	0x57	0x31	0x0A
'@'(Response)	PJ	Individual : 1	'P'	'W'	ON	End

By the above exchange, it can be confirmed that the projector's power state is ON.

Operation on projector screen

None

4.3 Input [InPut]

Used for input switching operation and referencing the input settings of the projector.

Setting is automatically stored in the projector when input is changed.

Command code

Table 4-5 INPUT CMD

HEX		ASCII		Function	Operation	Reference
0x49	0x50	'I'	'P'	Input switch [INPUT]	✓	✓

Parameters

Data length: 1 or 2

[Data 0]

Table 4-6 INPUT CMD DATA

HEX	ASCII	Operation
0x36	'6'	HDMI-1
0x37	'7'	HDMI-2

- The input switching operation is not done if the parameter data is sent to a terminal that is not provided on the projector.
- The toggle sequence follows the sequence of Operation panel on the projector.

4.3.1 Operation

Use the command as shown in the following examples.

Purpose: To switch the input to HDMI2. (Current input state: “HDMI-1”)

(1) Data is transmitted from the external controller to the projector as follows.

1: External controller →						
0x21	0x89	0x01	0x49	0x50	0x37	0x0A
'!(Operation)	PJ	Individual : 1	'I'	'P'	HDMI-2	End

(2) If projector receives data (1) and the command receipt is normal, an ACK is returned from the projector as follows.

2: ← Projector					
0x06	0x89	0x01	0x49	0x50	0x0A
ACK	PJ	Individual : 1	'I'	'P'	End

(3) The projector switches the input to HDMI-2.

Operation on the projector screen

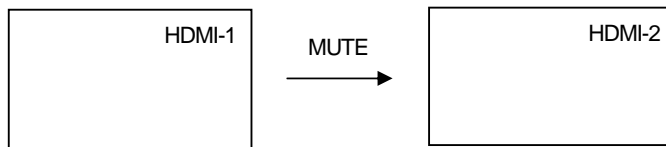

4.3.2 Reference

Use the command as shown in the following examples.

Purpose: To confirm the current projector output. (Current projector state: HDMI-2)

(1) Transmit the data from the external controller to the projector as follows.

1: External controller →					
0x3F	0x89	0x01	0x49	0x50	0x0A
'?(Reference)	PJ	Individual : 1	'I'	'P'	End

(2) If the projector receives the data (1) above and the command receipt is normal, an ACK is returned from the projector as follows.

2: ← Projector					
0x06	0x89	0x01	0x49	0x50	0x0A
ACK	PJ	Individual : 1	'I'	'P'	End

(3) The projector transmits information of input setting to the external controller.

3: ← Projector						
0x40	0x89	0x01	0x49	0x50	0x37	0x0A
'@(Response)	PJ	Individual : 1	'I'	'P'	HDMI-2	End

By the above exchange, it can be confirmed that the projector output state is in the HDMI-2 state.

Operation on the projector screen

None

4.4 Remote control pass-through [RemoteCode]

By selecting JVC remote control code, the same operation as user remote control can be achieved.

Remote control code consists of one byte of custom code and one byte of function/operation code.

Remote control code varies according to the projector and its state.

For the details of the remote control codes, see the key code specifications of each model.

Command code

Table 4-7 REMO CMD

HEX		ASCII		Function	Operation	Reference
0x52	0x43	'R'	'C'	Remote control pass-through [Remote Code]	✓	

Parameters

Data length: 4

Table 4-8 REMO CMD DATA

HEX	ASCII	Operation
0x30 ~ 0x39	'0' ~ '9'	Remote control code setting
0x41 ~ 0x46	'A' ~ 'F'	Remote control code setting

- ◆ The remote control code specification is in hexadecimal digits.
- ◆ The operation transition with the remote control codes is the same as from the user remote control.
- ◆ For the details of the remote control codes, see the key code specifications.

4.4.1 Operation

Use the command as shown in the following examples.

Purpose: To display MENU screen by press the “MENU” of remote control code [0x732E].

- (1) Transmit the data from the external controller to the projector as follows.

1: External controller →									
0x21	0x89	0x01	0x52	0x43	0x37	0x33	0x32	0x45	0x0A
!(Operation)	PJ	Individual : 1	'R'	'C'	'7'	'3'	'2'	'E'	End

- (2) If the projector receives the data (1) above and the command receipt is normal, an ACK is returned from the projector as follows.

2: ← Projector					
0x06	0x89	0x01	0x52	0x43	0x0A
ACK	PJ	Individual : 1	'R'	'C'	End

- (3) The projector produces a MENU screen.

By the above exchange, the MENU screen can be produced.

4.5 Setup [SetUp]

Used to change the initial setting.

Command code

Table 4-9 SETUP CMD

HEX		ASCII		Function
0x53	0X55R	'S'	'U'	Initial setting [SetUp]

Parameters

Data length: No regulation

Sub command table (Mandatory command only)

Table 4-10 SETUP CMD SUB

HEX		ASCII		Function	Last Memory	Operation	Reference
0x52	0x53	'R'	'S'	Switch the external control command protocol	No	✓	-
0x52	0x43	'R'	'C'	Switch the IR code	No	✓	✓

- ◆ It consists of "Sub command" + "Setting". The Sub command consists of ASCII character two bytes.

Sub commands parameters are as follow.

Parameters when the Sub command is [0x52,0x53] : Data length 1

HEX	ASCII	Operation
0x31	'1'	Compatible command system

Parameters when the Sub command is [0x52,0x43] : Data length 1

HEX	ASCII	Operation
0x30	'0'	A code(0x73)
0x31	'1'	B code(0x63)

4.5.1 Operation

Use the command as shown in the following examples.

Purpose: To switch External control command to compatible command protocol.

(1) Transmit the data from the external controller to the projector as follows.

1: External controller →								
0x21	0x89	0x01	0x53	0x55	0x52	0x53	0x31	0x0A
!(Operation)	PJ	Individual : 1	'S'	'U'	'R'	'S'	Compatible command protocol:1	End

(2) If the projector receives the data (1) above and the command receipt is normal, an ACK is returned from the projector as follows.

2: ← Projector					
0x06	0x89	0x01	0x53	0x55	0x0A
ACK	PJ	Individual : 1	'S'	'U'	End

(3) The projector switches external command protocol to Compatible command protocol.

By the above exchange, the projector switches to Compatible command protocol.

Operation on projector screen

None

4.6 Gamma data of Gamma table “Custom 1/2/3” [GammaRed, Green, Blue]

Used for sending operation of the gamma data when the Gamma table is Custom, and referencing the gamma data of the projector.

Target of switching and referencing is followed by setting value of the Gamma bank.

Command code

Table 4-11 GAMMA DATA CMD

HEX		ASCII		Function	Operation	Reference
0x47	0x52	'G'	'R'	Gamma data of the gamma table "Custom1/2/3" (Red) [GammaRed]	✓	✓
0x47	0x47	'G'	'G'	Gamma data of the gamma table "Custom1/2/3" (Green) [GammaGreen]	✓	✓
0x47	0x42	'G'	'B'	Gamma data of the gamma table "Custom1/2/3" (Blue) [GammaBlue]	✓	✓

Parameters

Data length: 512

The gamma data has 256 adjustment points composed of binary data.

The byte order is little endian.

- When the projector is not powered on and it receives the command, the projector ignores the command and does not respond.
- When the gamma table of the projector is not "Custom1", "Custom2" or "Custom3" and the projector receives the command, the projector ignores the command and does not respond.
- When the projector receives a gamma data by operation command, the projector saves the gamma data on proper area of EEPROM immediately.
- If the projector receives gamma data larger than 512 bytes, it is judged as invalid data and the projector does not respond.
- The curve is combination of the curve on the OSD and the table (Normal/A/B/C/D) in the video processor.

4.6.1 Operation

Use the command as shown in the following examples.

Purpose: To send red gamma data of the gamma table “Custom1/2/3” to the projector.

- (1) Transmit the data from the external controller to the projector as follows.

1: External controller →					
0x21	0x89	0x01	0x47	0x52	0x0A
!(Operation)	PJ	Individual : 1	'G'	'R'	End

- (2) If the projector receives the data (1) above and the command receipt is normal, an ACK is returned from the projector as follows.

2: ← Projector					
0x06	0x89	0x01	0x47	0x52	0x0A
ACK	PJ	Individual : 1	'G'	'R'	End

- (3) The external controller transmits 512 bytes of binary data to the projector.

- (4) If the projector receives data (3) above and the command receipt was normal, an ACK is returned from the projector as follows.

4: ← Projector					
0x06	0x89	0x01	0x47	0x52	0x0A
ACK	PJ	Individual : 1	'G'	'R'	End

4.6.2 Reference

Use the command as shown in the following examples.

**Purpose: To confirm the green gamma data of the current gamma table “Custom3”.
(Current Gamma bank: Custom3)**

- (1) Transmit the data from the external controller to the projector as follows.

1: External controller →					
0x3F	0x89	0x01	0x47	0x47	0x0A
?(Reference)	PJ	Individual : 1	'G'	'G'	End

- (2) If the projector receives the data (1) above and the command receipt is normal, an ACK is returned from the projector as follows.

2: ← Projector					
0x06	0x89	0x01	0x47	0x47	0x0A
ACK	PJ	Individual : 1	'G'	'G'	End

- (3) The projector transmits 512 bytes binary data to the external controller.

4.7 Panel Alignment (zone) Data [Panel Alignment (Zone) Red, Blue]

Used for transmitting operation and referencing Panel Alignment (zone) data

Command Code

Table 4-12 PANEL ALIGNMENT(ZONE) DATA CMD

HEX		ASCII		Function	transmitting	referencing
0x50	0x52	'P'	'R'	Data of Red [Panel Alignment(Zone)Red]	✓	✓
0x50	0x42	'P'	'B'	Data of Blue [Panel Alignment(Zone)Blue]	✓	✓

Parameters

Data Length: 256

Horizontal and Vertical data of 11x11 Adjustment zone composed of binary data. Data could be -31 (0xE1) to +31(0x1F).

Data is assigned by 2 bytes and its order is from Horizontal to Vertical. The order of Adjustment zone is shown at a table below.

$121 (\text{Adjustment zone}) \times 2 (\text{Horizontal / Vertical}) + 13 (\text{reserved}) = 256 \text{ Byte}$

Data No.	Horizontal position of zone	Vertical position of zone	Horizontal / Vertical
1	0	0	Horizontal
2			Vertical
3	1	0	Horizontal
4			Vertical
5	2	0	Horizontal
6			Vertical
(skip)			
21	10	0	Horizontal
22			Vertical
23	0	1	Horizontal
24			Vertical
(skip)			
239	9	10	Horizontal
240			Vertical
241	10	10	Horizontal
242			Vertical
243-256	Reserved		

The Byte order is little endian.

- ◆ When the projector is not powered on and it receives the command, the projector ignores the command and does not respond.
- ◆ If the projector receives gamma data larger than 256 bytes, it is judged as invalid data and the projector does not respond.

4.7.1 Operation

Use the command as shown in the following examples.

Purpose : To send red Alignment (zone) data to the projector.

(1) Transmit the data from the external controller to the projector as follows.

1: External Controller →					
0x21	0x89	0x01	0x50	0x52	0x0A
'!' (Operation)	PJ	Individual : 1	'P'	'R'	End

(2) If the projector receives the data (1) above and the command receipt is normal, an ACK is returned from the projector as follows.

2: ← Projector					
0x06	0x89	0x01	0x50	0x52	0x0A
ACK	PJ	Individual : 1	'P'	'R'	End

(3) The external controller transmits 256 bytes of binary data to the projector.

(4) If the projector receives data (3) above and the command receipt was normal, an ACK is returned from the projector as follows.

4: ← Projector					
0x06	0x89	0x01	0x50	0x52	0x0A
ACK	PJ	Individual : 1	'P'	'R'	End

4.7.2 Reference

Use the command as shown in the following examples.

Purpose : To confirm Blue data of the current Panel Alignment (zone)

(1) Transmit the data from the external controller to the projector as follows.

1: External Controller →					
0x3F	0x89	0x01	0x50	0x42	0x0A
'?' (reference)	PJ	Individual:1	'P'	'B'	End

(2) If the projector receives the data (1) above and the command receipt is normal, an ACK is returned from the projector as follows.

2: ← Projector					
0x06	0x89	0x01	0x50	0x42	0x0A
ACK	PJ	Individual : 1	'P'	'B'	End

(3) The projector transmits 256 bytes binary data to the external controller.

4.8 Source Asking [SourCe]

Use to refer signal input status of the projector.

Command code

Table 4-13 SOURCE CMD

HEX		ASCII		Function	Operation	Reference
0x53	0x43	'S'	'C'	Source asking [SourCe]		✓

Parameters

Data length: 1

[Data 0]

Table 4-14 SOURCE CMD DATA

HEX	ASCII	Operation
0x30	'0'	No signal or out of range
0x31	'1'	Available signal is input to the projector.

- When the projector is not powered on and it receives the command, the projector ignores the command and does not respond.

4.8.1 Reference

Use the command as shown in the following examples.

Purpose: To confirm the current status of the projector. (Current status: No signal or out of range)

- (1) Transmit the data from the external controller to the projector as follows.

1: External controller →					
0x3F	0x89	0x01	0x53	0x43	0x0A
'?(Reference)	PJ	Individual : 1	'S'	'C'	End

- (2) If the projector receives the data (1) above and the command receipt is normal, an ACK is returned from the projector as follows.

2: ← Projector					
0x06	0x89	0x01	0x53	0x43	0x0A
ACK	PJ	Individual : 1	'S'	'C'	End

- (3) The projector transmits the status of the input signal to the external controller.

3: ← Projector						
0x40	0x89	0x01	0x53	0x43	0x30	0x0A
'@(Response)	PJ	Individual : 1	'S'	'C'	No signal or out of range	End

By the above exchange, it can be confirmed that whether the status of input signal of the projector is no signal or out of range.

4.9 Model status asking [MoDel]

Used for referring model status of the projector.

Command code

Table 4-15 MODEL STATUS CMD

HEX		ASCII		Function	Operation	Reference
0x4D	0x44	'M'	'D'	Model status asking [MoDel]	-	✓

Parameters

Data length: 14

Table 4-16 MODEL STATUS CMD DATA

Parameters													
0x49	0x4C	0x41	0x46	0x50	0x4A	0x20	0x2D	0x2D	0x20	0x58	0x48	0x4B	(*)
'I'	'L'	'A'	'F'	'P'	'J'	SP	'_'	'_'	SP	'X'	'H'	'K'	'(*)'

(*) DLA-X500R,XC5880R,RS49 = '1'(0x31), DLA-RS4910 = '2' (0x32), DLA-X700R,XC7880R,RS57,X900R,RS6710 = '3' (0x33)

4.9.1 Reference

Use the command as shown in the following examples.

Purpose: To confirm the model status of the current projector.

- (1) Transmit the data from the external controller to the projector as follows.

1: External controller →					
0x3F	0x89	0x01	0x4D	0x44	0x0A
'?(Reference)	PJ	Individual : 1	'M'	'D'	End

- (2) If the projector receives the data (1) above and the command receipt is normal, an ACK is returned from the projector as follows.

2: ← Projector					
0x06	0x89	0x01	0x4D	0x44	0x0A
ACK	PJ	Individual : 1	'M'	'D'	End

- (3) The projector transmits a report of the model status to the external controller.

3: ← Projector						
0x40	0x89	0x01	0x4D	0x44	Parameters 14 bytes	0x0A
'@(Response)	PJ	Individual : 1	'M'	'D'	Model status	End

By the above exchange, it can be confirmed model status of the projector.

4.10 Adjustment [AdjustmentCommand]

Used for adjusting some function.

Command code

Table 4-17 ADJUSTMENT CMD

HEX		ASCII		Function
0x50	0x4D	'P'	'M'	Picture Adjust
0x49	0x53	'I'	'S'	Input Signal
0x49	0x4E	'I'	'N'	Installation
0x44	0x53	'D'	'S'	Display Setup
0x46	0X55R	'F'	'U'	Function
0x49	0x46	'I'	'F'	Information

Parameter1

Parameter1: Sub command

Data length: ASCII character 2 bytes

Parameter1 table is as follow.

Table 4-18 ADJUSTMENT CMD SUB

Command Code	Parameter1	Function	Operation	Reference	Data type	Model		
						X500R / RS49 / XC5880	RS4910	X700R/X900R XC7880 RS57/RS67 RS6710
'P' 'M' 'P' 'M'		Picture Mode switch	✓	✓	Special	✓	✓	✓
'P' 'M' 'A' 'N'		Clear Black	✓	✓	Special	✓	✓	✓
'P' 'M' 'D' 'I'		Intelligent Lens Aperture	✓	✓	Special	✓	✓	✓
'P' 'M' 'P' 'R'		Color Profile switch (*1)	✓	✓	Special	✓	✓	✓
'P' 'M' 'C' 'L'		Color Temperature table switch	✓	✓	Special	✓	✓	✓
'P' 'M' 'C' 'C'		Color Temperature Correction switch	✓	✓	Special	✓	✓	✓
'P' 'M' 'G' 'R'		Color Temperature Gain (Red) adjustment	✓	✓	Numeric	✓	✓	✓
'P' 'M' 'G' 'G'		Color Temperature Gain (Green) adjustment	✓	✓	Numeric	✓	✓	✓
'P' 'M' 'G' 'B'		Color Temperature Gain (Blue) adjustment	✓	✓	Numeric	✓	✓	✓
'P' 'M' 'O' 'R'		Color Temperature Offset (Red) adjustment	✓	✓	Numeric	✓	✓	✓
'P' 'M' 'O' 'G'		Color Temperature Offset (Green) adjustment	✓	✓	Numeric	✓	✓	✓
'P' 'M' 'O' 'B'		Color Temperature Offset (Blue) adjustment	✓	✓	Numeric	✓	✓	✓
'P' 'M' 'G' 'T'		Gamma Table switch	✓	✓	Special	✓	✓	✓
'P' 'M' 'F' 'W'		Picture Tone (White) adjustment	✓	✓	Numeric	✓	✓	✓
'P' 'M' 'F' 'R'		Picture Tone (Red) adjustment	✓	✓	Numeric	✓	✓	✓
'P' 'M' 'F' 'G'		Picture Tone (Green) adjustment	✓	✓	Numeric	✓	✓	✓
'P' 'M' 'F' 'B'		Picture Tone (Blue) adjustment	✓	✓	Numeric	✓	✓	✓
'P' 'M' 'C' 'N'		Contrast adjustment	✓	✓	Numeric	✓	✓	✓
'P' 'M' 'B' 'R'		Brightness adjustment	✓	✓	Numeric	✓	✓	✓
'P' 'M' 'C' 'O'		Color adjustment	✓	✓	Numeric	✓	✓	✓
'P' 'M' 'T' 'I'		Tint adjustment	✓	✓	Numeric	✓	✓	✓
'P' 'M' 'R' 'N'		NR adjustment	✓	✓	Numeric	✓	✓	✓
'P' 'M' 'G' 'C'		Gamma Correction switch	✓	✓	Special	✓	✓	✓
'P' 'M' 'D' 'R'		Gamma Red data	✓	✓	Special 2	✓	✓	✓
'P' 'M' 'D' 'G'		Gamma Green data	✓	✓	Special 2	✓	✓	✓
'P' 'M' 'D' 'B'		Gamma Blue data	✓	✓	Special 2	✓	✓	✓
'P' 'M' 'R' 'W'		Bright Level White	✓	✓	Numeric	✓	✓	✓
'P' 'M' 'R' 'R'		Bright Level Red	✓	✓	Numeric	✓	✓	✓
'P' 'M' 'R' 'G'		Dark Level Green	✓	✓	Numeric	✓	✓	✓
'P' 'M' 'R' 'B'		Dark Level Blue	✓	✓	Numeric	✓	✓	✓
'P' 'M' 'K' 'W'		Dark Level White	✓	✓	Numeric	✓	✓	✓
'P' 'M' 'K' 'R'		Dark Level Red	✓	✓	Numeric	✓	✓	✓
'P' 'M' 'K' 'G'		Dark Level Green	✓	✓	Numeric	✓	✓	✓

'P'	'M'	'K'	'B'	Dark Level Blue	✓	✓	Numeric	✓	✓	✓
'P'	'M'	'C'	'B'	Color Management table	✓	✓	Special	✓	✓	✓
'P'	'M'	'A'	'R'	Adjust Area (Red) adjustment	✓	✓	Numeric	✓	✓	✓
'P'	'M'	'A'	'O'	Adjust Area (Orange) adjustment	✓	✓	Numeric	✓	✓	✓
'P'	'M'	'A'	'Y'	Adjust Area (Yellow) adjustment	✓	✓	Numeric	✓	✓	✓
'P'	'M'	'A'	'G'	Adjust Area (Green) adjustment	✓	✓	Numeric	✓	✓	✓
'P'	'M'	'A'	'C'	Adjust Area (Cyan) adjustment	✓	✓	Numeric	✓	✓	✓
'P'	'M'	'A'	'B'	Adjust Area (Blue) adjustment	✓	✓	Numeric	✓	✓	✓
'P'	'M'	'A'	'M'	Adjust Area (Magenta) adjustment	✓	✓	Numeric	✓	✓	✓
'P'	'M'	'H'	'R'	HUE (Red) adjustment	✓	✓	Numeric	✓	✓	✓
'P'	'M'	'H'	'O'	HUE (Orange) adjustment	✓	✓	Numeric	✓	✓	✓
'P'	'M'	'H'	'Y'	HUE (Yellow) adjustment	✓	✓	Numeric	✓	✓	✓
'P'	'M'	'H'	'G'	HUE (Green) adjustment	✓	✓	Numeric	✓	✓	✓
'P'	'M'	'H'	'C'	HUE (Cyan) adjustment	✓	✓	Numeric	✓	✓	✓
'P'	'M'	'H'	'B'	HUE (Blue) adjustment	✓	✓	Numeric	✓	✓	✓
'P'	'M'	'H'	'M'	HUE (Magenta) adjustment	✓	✓	Numeric	✓	✓	✓
'P'	'M'	'S'	'R'	SATURATION (Red) adjustment	✓	✓	Numeric	✓	✓	✓
'P'	'M'	'S'	'O'	SATURATION (Orange) adjustment	✓	✓	Numeric	✓	✓	✓
'P'	'M'	'S'	'Y'	SATURATION (Yellow) adjustment	✓	✓	Numeric	✓	✓	✓
'P'	'M'	'S'	'G'	SATURATION (Green) adjustment	✓	✓	Numeric	✓	✓	✓
'P'	'M'	'S'	'C'	SATURATION (Cyan) adjustment	✓	✓	Numeric	✓	✓	✓
'P'	'M'	'S'	'B'	SATURATION (Blue) adjustment	✓	✓	Numeric	✓	✓	✓
'P'	'M'	'S'	'M'	SATURATION (Magenta) adjustment	✓	✓	Numeric	✓	✓	✓
'P'	'M'	'L'	'R'	BRIGHTNESS (Red) adjustment	✓	✓	Numeric	✓	✓	✓
'P'	'M'	'L'	'O'	BRIGHTNESS (Orange) adjustment	✓	✓	Numeric	✓	✓	✓
'P'	'M'	'L'	'Y'	BRIGHTNESS (Yellow) adjustment	✓	✓	Numeric	✓	✓	✓
'P'	'M'	'L'	'G'	BRIGHTNESS (Green) adjustment	✓	✓	Numeric	✓	✓	✓
'P'	'M'	'L'	'C'	BRIGHTNESS (Cyan) adjustment	✓	✓	Numeric	✓	✓	✓
'P'	'M'	'L'	'B'	BRIGHTNESS (Blue) adjustment	✓	✓	Numeric	✓	✓	✓
'P'	'M'	'L'	'M'	BRIGHTNESS (Magenta) adjustment	✓	✓	Numeric	✓	✓	✓
'P'	'M'	'C'	'M'	Clear Motion Drive	✓	✓	Special	✓	✓	✓
'P'	'M'	'L'	'A'	Lens Aperture	✓	✓	Numeric	✓	✓	✓
'P'	'M'	'L'	'P'	Lamp Power	✓	✓	Special	✓	✓	✓
'P'	'M'	'M'	'A'	MPC Analyze	✓	✓	Special	✓	✓	✓
'P'	'M'	'U'	'S'	4K e-shift	✓	✓	Special	✓	✓	✓
'P'	'M'	'R'	'P'	Resolution Profile	✓	✓	Special	✓	✓	✓
'P'	'M'	'E'	'N'	Enhance	✓	✓	Numeric	✓	✓	✓
'P'	'M'	'D'	'Y'	Dynamic Contrast	✓	✓	Numeric	✓	✓	✓
'P'	'M'	'S'	'T'	Smoothing	✓	✓	Numeric	✓	✓	✓
'P'	'M'	'U'	'1'	Name Edit of Picture Mode User1	✓	✓	Special 10	✓	✓	✓
'P'	'M'	'U'	'2'	Name Edit of Picture Mode User2	✓	✓	Special 10	✓	✓	✓
'P'	'M'	'U'	'3'	Name Edit of Picture Mode User3	✓	✓	Special 10	✓	✓	✓
'P'	'M'	'U'	'4'	Name Edit of Picture Mode User4	✓	✓	Special 10	✓	✓	✓
'P'	'M'	'U'	'5'	Name Edit of Picture Mode User5	✓	✓	Special 10	✓	✓	✓
'I'	'S'	'I'	'L'	HDMI Input Level switch	✓	✓	Special	✓	✓	✓
'I'	'S'	'H'	'S'	HDMI Color Space switch	✓	✓	Special	✓	✓	✓
'I'	'S'	'C'	'E'	HDMI CEC switch	✓	✓	Special	✓	✓	✓
'I'	'S'	'3'	'D'	HDMI 2D/3D switch	✓	✓	Special	✓	✓	✓
'I'	'S'	'3'	'P'	HDMI 3D Phase adjustment	✓	✓	Numeric	✓	✓	✓
'I'	'S'	'P'	'H'	Picture Position (Horizontal) adjustment	✓	✓	Numeric	✓	✓	✓
'I'	'S'	'P'	'V'	Picture Position (Vertical) adjustment	✓	✓	Numeric	✓	✓	✓
'I'	'S'	'A'	'S'	Aspect switch	✓	✓	Special	✓	✓	✓
'I'	'S'	'M'	'A'	Mask switch	✓	✓	Special	✓	✓	✓
'I'	'S'	'M'	'L'	Mask (Left) adjustment	(*2)	✓	Numeric	✓	✓	✓
'I'	'S'	'M'	'R'	Mask (Right) adjustment	(*2)	✓	Numeric	✓	✓	✓
'I'	'S'	'M'	'T'	Mask (Top) adjustment	(*2)	✓	Numeric	✓	✓	✓
'I'	'S'	'M'	'B'	Mask (Bottom) adjustment	(*2)	✓	Numeric	✓	✓	✓
'I'	'S'	'F'	'M'	Film Mode switch	✓	✓	Special	✓	✓	✓
'I'	'S'	'3'	'C'	3D conversion switch	✓	✓	Special	✓	✓	✓
'I'	'S'	'L'	'V'	Parallax of 3D conversion adjustment	✓	✓	Numeric	✓	✓	✓
'I'	'S'	'C'	'A'	Crosstalk Cancel (White) adjustment	✓	✓	Numeric	✓	✓	✓
'I'	'N'	'F'	'N'	Focus Near adjustment (*3)	✓	✓	Special	✓	✓	✓
'I'	'N'	'F'	'F'	Focus Far adjustment (*3)	✓	✓	Special	✓	✓	✓
'I'	'N'	'Z'	'T'	Zoom Tele adjustment (*3)	✓	✓	Special	✓	✓	✓
'I'	'N'	'Z'	'W'	Zoom Wide adjustment (*3)	✓	✓	Special	✓	✓	✓
'I'	'N'	'S'	'L'	Shift Left adjustment (*3)	✓	✓	Special	✓	✓	✓
'I'	'N'	'S'	'R'	Shift Right adjustment (*3)	✓	✓	Special	✓	✓	✓

'I'	'N'	'S'	'U'	Shift Up adjustment (*3)	✓	✓	Special	✓	✓	✓
'I'	'N'	'S'	'D'	Shift Down adjustment (*3)	✓	✓	Special	✓	✓	✓
'I'	'N'	'C'	'V'	Lens Cover switch	✓	✓	Special	-	-	✓
'I'	'N'	'I'	'P'	Image Pattern switch	✓	✓	Special	✓	✓	✓
'I'	'N'	'L'	'L'	Lens Lock switch	✓	✓	Special	✓	✓	✓
'I'	'N'	'X'	'R'	Pixel Adjust (Horizontal Red) adjustment	✓	✓	Numeric	✓	✓	✓
'I'	'N'	'X'	'B'	Pixel Adjust (Horizontal Blue) adjustment	✓	✓	Numeric	✓	✓	✓
'I'	'N'	'Y'	'R'	Pixel Adjust (Vertical Red) adjustment	✓	✓	Numeric	✓	✓	✓
'I'	'N'	'Y'	'B'	Pixel Adjust (Vertical Blue) adjustment	✓	✓	Numeric	✓	✓	✓
'I'	'N'	'I'	'S'	Installation Style switch	✓	✓	Special	✓	✓	✓
'I'	'N'	'K'	'V'	Keystone (Vertical) adjustment	✓	✓	Numeric	✓	✓	✓
'I'	'N'	'D'	'I'	Pincushion	✓	✓	Numeric	✓	✓	✓
'I'	'N'	'V'	'S'	Anamorphic switch	✓	✓	Special	✓	✓	✓
'I'	'N'	'S'	'A'	Screen Adjust Data	✓	✓	Numeric	✓	✓	✓
'I'	'N'	'S'	'C'	Screen Adjust switch	✓	✓	Special	✓	✓	✓
'I'	'N'	'S'	'E'	Environment Correction	✓	✓	Special	✓	✓	✓
'I'	'N'	'S'	'S'	Screen Size	✓	✓	Special	✓	✓	✓
'I'	'N'	'V'	'D'	Viewing Distance	✓	✓	Special	✓	✓	✓
'I'	'N'	'W'	'C'	Wall Color	✓	✓	Special	✓	✓	✓
'I'	'N'	'P'	'A'	Panel Alignment switch	✓	✓	Special	✓	✓	✓
'I'	'N'	'M'	'S'	Store Lens memory	✓	✓	Special 9	✓	✓	✓
'I'	'N'	'M'	'L'	Load Lens memory	✓	-	Special	✓	✓	✓
'I'	'N'	'M'	'1'	Name Edit of Lens Memory 1	✓	✓	Special 10	✓	✓	✓
'I'	'N'	'M'	'2'	Name Edit of Lens Memory 2	✓	✓	Special 10	✓	✓	✓
'I'	'N'	'M'	'3'	Name Edit of Lens Memory 3	✓	✓	Special 10	✓	✓	✓
'I'	'N'	'M'	'4'	Name Edit of Lens Memory 4	✓	✓	Special 10	✓	✓	✓
'I'	'N'	'M'	'5'	Name Edit of Lens Memory 5	✓	✓	Special 10	✓	✓	✓
'I'	'N'	'M'	'6'	Name Edit of Lens Memory 6	✓	✓	Special 10	✓	✓	✓
'I'	'N'	'M'	'7'	Name Edit of Lens Memory 7	✓	✓	Special 10	✓	✓	✓
'I'	'N'	'M'	'8'	Name Edit of Lens Memory 8	✓	✓	Special 10	✓	✓	✓
'I'	'N'	'M'	'9'	Name Edit of Lens Memory 9	✓	✓	Special 10	✓	✓	✓
'I'	'N'	'M'	'A'	Name Edit of Lens Memory 10	✓	✓	Special 10	✓	✓	✓
'I'	'N'	'1'	'N'	Focus Near adjustment (1 shot)(*3)	✓	✓	None	✓	✓	✓
'I'	'N'	'1'	'F'	Focus Far adjustment (1 shot) (*3)	✓	✓	None	✓	✓	✓
'I'	'N'	'1'	'T'	Zoom Tele adjustment (1 shot) (*3)	✓	✓	None	✓	✓	✓
'I'	'N'	'1'	'W'	Zoom Wide adjustment (1 shot) (*3)	✓	✓	None	✓	✓	✓
'I'	'N'	'1'	'L'	Shift Left adjustment (1 shot) (*3)	✓	✓	None	✓	✓	✓
'I'	'N'	'1'	'R'	Shift Right adjustment (1 shot) (*3)	✓	✓	None	✓	✓	✓
'I'	'N'	'1'	'U'	Shift Up adjustment (1 shot) (*3)	✓	✓	None	✓	✓	✓
'I'	'N'	'1'	'D'	Shift Down adjustment (1 shot) (*3)	✓	✓	None	✓	✓	✓
'I'	'N'	'H'	'A'	High Altitude mode switch	✓	✓	Special	✓	✓	✓
'D'	'S'	'B'	'C'	Back Color switch	✓	✓	Special	✓	✓	✓
'D'	'S'	'M'	'P'	Menu Position switch	✓	✓	Special	✓	✓	✓
'D'	'S'	'S'	'D'	Source Display switch	✓	✓	Special	✓	✓	✓
'D'	'S'	'L'	'O'	Logo switch	✓	✓	Special	✓	✓	✓
'D'	'S'	'L'	'A'	Language switch	✓	✓	Special	✓	✓	✓
'F'	'U'	'T'	'R'	Trigger switch	✓	✓	Special	✓	✓	✓
'F'	'U'	'O'	'T'	Off Timer switch	✓	✓	Special	✓	✓	✓
'F'	'U'	'E'	'M'	Eco Mode switch	✓	✓	Special	✓	✓	✓
'I'	'F'	'I'	'N'	Input display	-	✓	Special	✓	✓	✓
'I'	'F'	'I'	'S'	Source display	-	✓	Special	✓	✓	✓
'I'	'F'	'R'	'H'	Horizontal Resolution display	-	✓	Numeric	✓	✓	✓
'I'	'F'	'R'	'V'	Vertical Resolution display	-	✓	Numeric	✓	✓	✓
'I'	'F'	'F'	'H'	Horizontal Frequency display (*4)	-	✓	Numeric	✓	✓	✓
'I'	'F'	'F'	'V'	Vertical Frequency display (*4)	-	✓	Numeric	✓	✓	✓
'I'	'F'	'D'	'C'	Deep Color display	-	✓	Special	✓	✓	✓
'I'	'F'	'X'	'V'	Color space display	-	✓	Special	✓	✓	✓
'I'	'F'	'L'	'T'	Lamp Time display	-	✓	Numeric	✓	✓	✓
'I'	'F'	'S'	'V'	Soft Version Display	-	✓	Special 14	✓	✓	✓
'I'	'F'	'C'	'I'	Calibrator Information transmission/display (*5)	-	✓	Special 3	✓	✓	✓
'P'	'M'	'C'	'I'	Calibrator Information transmission/display (*5)	✓	✓	Special 3	-	✓	✓

(*1) Only the parameter that follows Picture Mode is effective. (Refer to the table of Picture Mode vs. Color Profile that described in "Color Profile" section of Functional Spec.)

[Example] Picture Mode = Natural Video(0x38) -> Accepted, Anime1(0x36) -> Rejected
Picture Mode = Film Film1(0x31) -> Accepted, Standard(0x33) -> Rejected

If the corresponded parameter is only one, PJ ignores setting command.

(*2) Setting operations of Mask Left / Right / Top / Bottom [ISML, ISMR, ISMT, ISMB] command are only effective when Mask Setting [ISMA] is set to "Custom".

(*3) Because of electrical limitation, only one motor can be driven at the same time.(Same as 1 shot mode)

If the projector receives a motor drive request when other motor is driving, the projector rejects its request.

When a driving motor reaches its limit, the projector stops the motor automatically.

(*4) Parameter is equal to the result in which 100 is multiplied with the actual value.

[Example] When Horz. Frequency is 63.98 kHz : Parameter = $63.98 * 100 = 6398 = 0x18FE$

(*5) Both commands are completely same.

Parameter2

Parameter2 data depends on Sub command.

Data length is as follow depending on Sub command.

Data type	Data length	Note
Numeric	4 bytes	ASCII character
Special	1 byte	ASCII character
Special2	512 bytes	Binary data(for Gamma)
Special3	18 bytes	ASCII character (Information for Calibrator)
Special4	2 bytes	ASCII character
Special5	384 bytes	Binary data
Special6	2 bytes	ASCII character
Special7	384 bytes	Binary data
Special9	1 byte(operation) /3 byte (reference)	ASCII character
Special10	10 bytes	ASCII character
Special13	2 bytes	ASCII character
Special14	6 bytes	ASCII character

- ◆ When the projector is not powered on and it receives the command, the projector ignores the command and does not respond.

4.10.1 Special data

Picture mode

Table 4-19 PICTURE MODE CMD DATA

HEX	ASCII	Operation	X500R, XC5880, RS49	RS4910	X700R, XC7880, RS57 X900R, RS6710
0x30 0x30	0 0	Film	-	-	✓
0x30 0x31	0 1	Cinema	✓	✓	✓
0x30 0x32	0 2	Animation	✓	✓	✓
0x30 0x33	0 3	Natural	✓	✓	✓
0x30 0x34	0 4	Stage	✓	✓	✓
0x30 0x36	0 6	THX	-	-	✓
0x30 0x42	0 B	4K 50/60P(*3)	✓	✓	✓
0x30 0x43	0 C	User1	✓	✓	✓
0x30 0x44	0 D	User2	✓	✓	✓
0x30 0x45	0 E	User3	✓	✓	✓
0x30 0x46	0 F	User4	✓	✓	✓
0x31 0x32	1 2	Photo	-	-	✓

(*3)Reference only

Clear Black

Table 4-20 CLEAR BLACK CMD DATA

HEX	ASCII	Operation	X500R, XC5880, RS49	RS4910	X700R, XC7880, RS57 X900R, RS6710
0x30	0	Off	✓	✓	✓
0x31	1	Low	✓	✓	✓
0x32	2	High	✓	✓	✓

Intelligent Lens Aperture

Table 4-21 INTELLIGENT LENS APERTURE CMD DATA

HEX	ASCII	Operation	X500R, XC5880, RS49	RS4910	X700R, XC7880, RS57 X900R, RS6710
0x30	0	Off	✓	✓	✓
0x31	1	Mode1	✓	✓	✓
0x32	2	Mode2	✓	✓	✓

Color Profile

Table 4-22 COLOR PROFILE CMD DATA

HEX	ASCII	Operation	X500R,XC5880,R S49	RS4910	X700R,XC7880,R S57 X900R,RS6710
0x30 0x30	0 0	Off	✓	✓	✓
0x30 0x31	0 1	Film1	-	-	✓
0x30 0x32	0 2	Film2	-	-	✓
0x30 0x33	0 3	Standard	✓	✓	✓
0x30 0x34	0 4	Cinema1	✓	✓	✓
0x30 0x35	0 5	Cinema2	-	-	✓
0x30 0x36	0 6	Anime1	✓	✓	✓
0x30 0x37	0 7	Anime2	-	-	✓
0x30 0x38	0 8	Video	✓	✓	✓
0x30 0x39	0 9	x.v.Color	-	-	✓
0x30 0x41	0 A	Adobe	-	-	✓
0x30 0x42	0 B	Stage	✓	✓	✓
0x30 0x43	0 C	3D Cinema	✓	✓	✓
0x30 0x44	0 D	THX	-	-	✓
0x30 0x45	0 E	Custom1	✓	✓	✓
0x30 0x46	0 F	Custom2	✓	✓	✓
0x31 0x30	1 0	Custom3	✓	✓	✓
0x31 0x31	1 1	Custom4	✓	✓	✓
0x31 0x32	1 2	Custom5	✓	✓	✓
0x31 0x33	1 3	Film3	-	-	✓
0x31 0x34	1 4	3D Video	✓	✓	✓
0x31 0x35	1 5	3D Anime	✓	✓	✓
0x31 0x36	1 6	3D Photo	-	-	✓
0x31 0x45	1 E	3D Film	-	-	✓
0x31 0x46	1 F	3D Stage	✓	✓	✓
0x32 0x30	2 0	3D THX	-	-	✓

Color Temp. Table Data

Table 4-23 COLOR TEMP TABLE CMD DATA

HEX	ASCII	Operation
0x30	'0'	5500K
0x31	'1'	6000K
0x32	'2'	6500K
0x33	'3'	7000K
0x34	'4'	7500K
0x35	'5'	8000K
0x36	'6'	8500K
0x37	'7'	9000K
0x38	'8'	9500K
0x39	'9'	High Bright
0x41	'A'	Custom1
0x42	'B'	Custom2
0x43	'C'	Custom3
0x44	'D'	Xenon1
0x45	'E'	Xenon2
0x46	'F'	Xenon3

Color Temp. Correction Data

Table 4-24 COLOR TEMP CORRECTION CMD DATA

HEX	ASCII	Operation
0x30	'0'	5500K
0x31	'1'	6000K
0x32	'2'	6500K
0x33	'3'	7000K
0x34	'4'	7500K
0x35	'5'	8000K
0x36	'6'	8500K
0x37	'7'	9000K
0x38	'8'	9500K
0x39	'9'	High Bright
0x44	'D'	Xenon1
0x45	'E'	Xenon2
0x46	'F'	Xenon3

Gamma Table Data

Table 4-25 GAMMA CMD DATA

HEX	ASCII	Operation
0x30	'0'	Normal
0x31	'1'	Bright Priority
0x32	'2'	Cont Priority
0x33	'3'	Grad Priority
0x34	'4'	Custom1
0x35	'5'	Custom2
0x36	'6'	Custom3
0x41	'A'	Film1
0x42	'B'	Film2

Gamma Correction Data

Table 4-26 GAMMA CORRECTION CMD DATA

HEX	ASCII	Operation
0x30	'0'	Normal
0x31	'1'	Bright Priority
0x32	'2'	Cont Priority
0x33	'3'	Grad Priority
0x34	'4'	Import
0x35	'5'	1.8
0x36	'6'	1.9
0x37	'7'	2.0
0x38	'8'	2.1
0x39	'9'	2.2
0x41	'A'	2.3
0x42	'B'	2.4
0x43	'C'	2.5
0x44	'D'	2.6
0x45	'E'	Film1
0x46	'F'	Film2

Color Management Data

Table 4-27 COLOR MANAGEMENT CMD DATA

HEX	ASCII	Operation
0x30	'0'	Off
0x31	'1'	Custom1
0x32	'2'	Custom2
0x33	'3'	Custom3

CMS Display Color Data

Table 4-28 CMS DISPLAY COLOR CMD DATA

HEX	ASCII	Operation
0x30	'0'	All Color
0x31	'1'	Select Color

Clear Motion Drive Data

Table 4-29 CLEAR MOTION DRIVE CMD DATA

HEX	ASCII	Operation
0x30	'0'	Off
0x33	'3'	Low
0x34	'4'	High
0x35	'5'	Inverse Telecine

Lamp Power Data

Table 4-30 LAMP POWER CMD DATA

HEX	ASCII	Operation
0x30	'0'	Normal
0x31	'1'	High

MPC Analyze Data

Table 4-31 MPC ANALYZE CMD DATA

HEX	ASCII	Operation
0x30	'0'	Off
0x31	'1'	Analyze
0x32	'2'	Analyze Enhance
0x33	'3'	Analyze Dynamic Contrast
0x34	'4'	Analyze Smoothing
0x35	'5'	Analyze histogram

4K e-shift Data

Table 4-32 4K e-shift CMD DATA

HEX	ASCII	Operation
0x30	'0'	Off
0x31	'1'	On

HDMI Input Level Data

Table 4-33 HDMI INPUT LEVEL CMD DATA

HEX	ASCII	Operation
0x30	'0'	Standard(16-235)
0x31	'1'	Enhanced(0-255)
0x32	'2'	Super White(16-255)
0x33	'3'	Auto

HDMI Color Space Data

Table 4-34 HDMI COLOR SPACE CMD DATA

HEX	ASCII	Operation
0x30	'0'	Auto
0x31	'1'	YCbCr(4:4:4)
0x32	'2'	YCbCr(4:2:2)
0x33	'3'	RGB

HDMI CEC Data

Table 4-35 HDMI CEC CMD DATA

HEX	ASCII	Operation
0x30	'0'	Off
0x31	'1'	On

HDMI 2D/3D Data

Table 4-36 HDMI 2D/3D CMD DATA

HEX	ASCII	Operation
0x30	'0'	2D
0x31	'1'	Auto
0x33	'3'	Side By Side
0x34	'4'	Top and Bottom

HDMI 3D Phase Data

Table 4-37 HDMI 3D Phase CMD DATA

HEX	ASCII	Operation
0x30	'0'	Standard
0x31	'1'	Flip

Aspect Data

Table 4-38 ASPECT CMD DATA

HEX	ASCII	Operation
0x30	'0'	4:3
0x31	'1'	16:9
0x32	'2'	Zoom
0x33	'3'	Auto
0x34	'4'	Just
0x35	'5'	Full

Mask Data

Table 4-39 MASK CMD DATA

HEX	ASCII	Operation
0x30	'0'	2.5%
0x31	'1'	5%
0x32	'2'	Off
0x33	'3'	Custom

3D Conversion Switch Data

Table 4-40 3D CONVERSION CMD DATA

HEX	ASCII	Operation
0x30	'0'	Off
0x31	'1'	On

Lens Control(Focus Near, Focus Far, Zoom Tele, Zoom Wide, Shift Left, Shift Right, Shift Up, Shift Down) Data

Table 4-41 LENS CONTROL (Focus / Zoom / Shift) CMD DATA

HEX	ASCII	Operation
0x30	'0'	Stop
0x31	'1'	Start

Lens Cover Data

Table 4-42 LENS COVER CMD DATA

HEX	ASCII	Operation
0x30	'0'	Auto
0x31	'1'	Open

Lens Image Pattern, Lens Lock, Environment Correction, Screen Adjust Data

Table 4-43 Above CMD DATA

HEX	ASCII	Operation
0x30	'0'	Off
0x31	'1'	On

Installation Style Data

Table 4-44 INSTALLATION STYLE CMD DATA

HEX	ASCII	Operation
0x30	'0'	Front
0x31	'1'	Ceiling Mount (F)
0x32	'2'	Rear
0x33	'3'	Ceiling Mount (R)

Anamorphic Data

Table 4-45 ANAMORPHIC CMD DATA

HEX	ASCII	Operation
0x30	'0'	Off
0x31	'1'	A
0x32	'2'	B

Panel Alignment Switch Data

Table 4-46 PANEL ALIGNMENT CMD DATA

HEX	ASCII	Operation
0x30	'0'	Off
0x31	'1'	Mode1
0x31	'2'	Mode2

Screen Size Data

Table 4-47 SCREEN SIZE CMD DATA

HEX	ASCII	Operation
0x30	0	60inch
0x31	1	70inch
0x32	2	80inch
0x33	3	90inch
0x34	4	100inch
0x35	5	110inch
0x36	6	120inch
0x37	7	130inch
0x38	8	140inch
0x39	9	150inch
0x41	A	160inch
0x42	B	170inch
0x43	C	180inch
0x44	D	190inch
0x45	E	200inch

High Altitude mode Data

Table 4-48 HIGH ALTITUDE CMD DATA

HEX	ASCII	Operation
0x30	'0'	Off
0x31	'1'	On

Viewing Distance Data

Table 4-49 VIEWING DISTANCE CMD DATA

HEX	ASCII	Operation
0x30	0	1m
0x31	1	2m
0x32	2	3m
0x33	3	4m
0x34	4	5m
0x35	5	6m
0x36	6	7m
0x37	7	8m
0x38	8	9m
0x39	9	10m

Wall Color Data

Table 4-50 WALL COLOR CMD DATA

HEX	ASCII	Operation
0x30	'0'	Dark
0x31	'1'	Light

Lens Memory Save Data

Table 4-51 LENS MEMORY SAVE CMD DATA

HEX	ASCII	Operation	X500R, XCS880, RS49	RS4910	X700R, XC7880, RS67 X900R, RS6710
0x30	0	Memory1	✓	✓	✓
0x31	1	Memory2	✓	✓	✓
0x32	2	Memory3	✓	✓	✓
0x33	3	Memory4	✓	✓	✓
0x34	4	Memory5	✓	✓	✓
0x35	5	Memory6	-	-	✓
0x36	6	Memory7	-	-	✓
0x37	7	Memory8	-	-	✓
0x38	8	Memory9	-	-	✓
0x39	9	Memory10	-	-	✓

Back Color Data

Table 4-52 BACK COLOR CMD DATA

HEX	ASCII	Operation
0x30	'0'	Blue
0x31	'1'	Black

Menu Position Data

Table 4-53 MENU POSITION CMD DATA

HEX	ASCII	Operation
0x30	'0'	Left-Top
0x31	'1'	Right-Top
0x32	'2'	Center
0x33	'3'	Left-Bottom
0x34	'4'	Right-Bottom
0x35	'5'	Left
0x36	'6'	Right

Source Display, Logo Data

Table 4-54 Source Display, Logo CMD DATA

HEX	ASCII	Operation
0x30	'0'	Off
0x31	'1'	On

Language Data

Table 4-55 LANGUAGE CMD DATA

HEX	ASCII	Operation
0x30	'0'	Japanese
0x31	'1'	English
0x32	'2'	German
0x33	'3'	Spanish
0x34	'4'	Italian
0x35	'5'	French
0x36	'6'	Portuguese
0x37	'7'	Dutch
0x38	'8'	Swedish
0x39	'9'	Norwegian
0x41	'A'	Russian
0x42	'B'	Chinese(Simplified Chinese)
0x43	'C'	Chinese (Traditional Chinese)

Trigger Data

Table 4-56 TRIGGER CMD DATA

HEX	ASCII	Operation
0x30	'0'	Off
0x31	'1'	On(Power)
0x32	'2'	On(Anamo)

Off Timer Data

Table 4-57 OFF TIMER CMD DATA

HEX	ASCII	Operation
0x30	'0'	Off
0x31	'1'	1 Hour
0x32	'2'	2 Hours
0x33	'3'	3 Hours
0x34	'4'	4 Hours

Eco Mode Data

Table 4-58 ECO MODE CMD DATA

HEX	ASCII	Operation
0x30	'0'	Off
0x31	'1'	On

Input Data

Table 4-59 INPUT CMD DATA

HEX	ASCII	Operation
0x36	'6'	HDMI-1
0x37	'7'	HDMI-2

Source Data

Table 4-60 SOURCE CMD DATA

HEX	ASCII	Operation
0x30	'0'	480i
0x31	'1'	576i
0x32	'2'	480p
0x33	'3'	576p
0x34	'4'	720p50
0x35	'5'	720p60
0x36	'6'	1080i50
0x37	'7'	1080i60
0x38	'8'	1080p24
0x39	'9'	1080p50
0x41	'A'	1080p60
0x42	'B'	No signal
0x43	'C'	720p 3D
0x44	'D'	1080i 3D
0x45	'E'	1080p 3D
0x46	'F'	4K

Deep Color Data

Table 4-61 DEEP COLOR CMD DATA

HEX	ASCII	Operation
0x30	'0'	8 bit
0x31	'1'	10 bit
0x32	'2'	12 bit

Color Space Data

Table 4-62 COLOR SPACE CMD DATA

HEX	ASCII	Operation
0x30	'0'	RGB
0x31	'1'	YUV
0x32	'2'	x.v.Color

4.10.2 Special2 Data

This is the same as Gamma data [GammaRed, Green, Blue] of Gamma table "Custom 1/2/3".

4.10.3 Special3 Data

This is the same as Model Status Asking [MoDel].

4.10.4 Special9 Data

Parameter relating to save lens memory. Parameter format and meanings are depend on <Operation.> and <Reference.>.

<Operation.>

Table 4-63 LENS MEMORY SAVE CMD DATA<operation.>

HEX	ASCII	Operation	Operation		
			X500R,XC5880, RS49	RS4910	X700R,XC7880, RS57 X900R,RS6710
0x30	0	Memory1	✓	✓	✓
0x31	1	Memory2	✓	✓	✓
0x32	2	Memory3	✓	✓	✓
0x33	3	Memory4	✓	✓	✓
0x34	4	Memory5	✓	✓	✓
0x35	5	Memory6	-	-	✓
0x36	6	Memory7	-	-	✓
0x37	7	Memory8	-	-	✓
0x38	8	Memory9	-	-	✓
0x39	9	Memory10	-	-	✓

<Reference.>

Saved condition on Memory1/2/3 (Either Not-Saved / saved) is returned with 1 byte each. 3 bytes in Total are returned.

Table 4-64 LENS MEMORY SAVE CMD DATA<Reference.>

HEX	ASCII	Operation
0x30	'0'	Not- Saved
0x31	'1'	Saved

4.10.5 Special10 Data

Parameter relating to editing names of Lens Memory 1/2/3/4/5/6/7/8/9/10 and User 1/2/3 in Picture Mode. 10 Byte ASCII characters.

Communication format is same as Calibrator information transmission/display [PMCI].

4.10.6 Special14 Data

Data Length: 6

2 byte +0x2D ('-') +3 byte

4.10.7 Operation

Use the command as shown in the following examples.

(Example 1) Switching Picture Mode

Purpose: To set Color Temp. Table to '6500K'

(1) Transmitting Data from External controller to Projector as follows.

1: External Controller →								
0x21	0x89	0x01	0x50	0x4D	0x43	0x4C	0x32	0x0A
!' (Operation)	PJ	Individual : 1	'P'	'M'	'C'	'L'	6500K	End

(2) If the projector receives the data (1) above and the command receipt is normal, an ACK is returned from the projector as follows.

2: ← Projector					
0x06	0x89	0x01	0x50	0x4D	0x0A
ACK	PJ	Individual : 1	'P'	'M'	End

(3) The projector sets the Color Temp. Table to '6500K'.

(Example 2) Contrast adjustment

Purpose: To set Contrast to +20.

(1) Transmit the data from the external controller to the projector as follows.

1: External controller →											
0x21	0x89	0x01	0x50	0x4D	0x43	0x4E	0x30	0x30	0x31	0x34	0x0A
!'(Operation)	PJ	Individual : 1	'P'	'M'	'C'	'N'	'0'	'0'	'1'	'4'	End

(2) If the projector receives the data (1) above and the command receipt is normal, an ACK is returned from the projector as follows.

2: ← Projector					
0x06	0x89	0x01	0x50	0x4D	0x0A
ACK	PJ	Individual : 1	'P'	'M'	End

(3) The projector sets the contrast to +20.

(Example 3) Gamma adjustment

Purpose: To transmit gamma data of red to the projector.

(1) Transmit the data from the external controller to the projector as follows.

1: External controller →							
0x21	0x89	0x01	0x50	0x4D	0x44	0x52	0x0A
!'(Operation)	PJ	Individual : 1	'P'	'M'	'D'	'R'	End

(2) If the projector receives the data (1) above and the command receipt is normal, an ACK is returned from the projector as follows.

2: ← Projector					
0x06	0x89	0x01	0x50	0x4D	0x0A
ACK	PJ	Individual : 1	'P'	'M'	End

(3) The external controller sends 512 bytes binary data to the projector.

3: External controller →	
512 byte	
Data parameter	

(4) If the projector receives data (3) above and receipt was normal, an ACK is returned from the projector as follows.

4: ← Projector					
0x06	0x89	0x01	0x50	0x4D	0x0A
ACK	PJ	Individual : 1	'P'	'M'	End

4.10.8 Reference

Use the command as shown in the following examples.

(Example1) Confirm Picture Mode

Purpose: To Confirm Current Picture Mode (Picture Mode: Natural)

(1) Transmit the data from the external controller to the projector as follows.

1: External Controller →							
0x3F	0x89	0x01	0x50	0x4D	0x50	0x4D	0x0A
'?(Reference)	PJ	Individual : 1	'P'	'M'	'P'	'M'	End

(2) If the projector receives the data (1) above and the command receipt is normal, an ACK is returned from the projector as follows.

2: ← Projector					
0x06	0x89	0x01	0x50	0x4D	0x0A
ACK	PJ	Individual : 1	'P'	'M'	End

(3) Then, the projector transmits Picture Mode to the External Controller.

3: ← Projector							
0x40	0x89	0x01	0x50	0x4D	0x30	0x33	0x0A
'@(Reference)	PJ	Individual: 1	'P'	'M'	Natural		End

By the above exchange, it can be confirmed that the projector's Picture Mode is 'Natural'.

(Example 2) Brightness confirmation

Purpose: To confirm the brightness. (Current brightness: -3)

(1) Transmit the data from the external controller to the projector as follows.

1: External controller →							
0x3F	0x89	0x01	0x50	0x4D	0x42	0x52	0x0A
'?(Reference)	PJ	Individual : 1	'P'	'M'	'B'	'R'	End

(2) If the projector receives the data (1) above and the command receipt is normal, an ACK is returned from the projector as follows.

2: ← Projector					
0x06	0x89	0x01	0x50	0x4D	0x0A
ACK	PJ	Individual : 1	'P'	'M'	End

(3) The projector transmits brightness setting "-3" to the external controller.

3: ← Projector									
0x40	0x89	0x01	0x50	0x4D	0x46	0x46	0x46	0x44	0x0A
'@(Response)	PJ	Individual : 1	'P'	'M'	'F'	'F'	'F'	'D'	End

By the above exchange, it can be confirmed that the projector's brightness is set to "-3".

(Example 3) Gamma confirmation

Purpose: To confirm the Green gamma data.

(1) Transmit the data from the external controller to the projector as follows.

1: External controller →							
0x3F	0x89	0x01	0x50	0x4D	0x44	0x47	0x0A
'?(Reference)	PJ	Individual : 1	'P'	'M'	'D'	'G'	End

(2) If the projector receives the data (1) above and the command receipt is normal, an ACK is returned from the projector as follows.

2: ← Projector					
0x06	0x89	0x01	0x50	0x4D	0x0A
ACK	PJ	Individual : 1	'P'	'M'	End

(3) The projector transmits 512 bytes binary data to the external controller.

(Example 4) Confirm Software Version

Purpose: Confirm Software Version

(1) Transmit the data from the external controller to the projector as follows.

1: External Controller →							
0x3F	0x89	0x01	0x49	0x46	0x53	0x56	0x0A
'?' (Reference)	PJ	Individual:1	'I'	'F'	'S'	'V'	End

(2) If the projector receives the data (1) above and the command receipt is normal, an ACK is returned from the projector as follows.

2: ← Projector					
0x06	0x89	0x01	0x49	0x46	0x0A
ACK	PJ	Individual : 1	'I'	'F'	End

(3) Then, the Projector transmits Software version to the external controller.

3: ← Projector											
0x06	0x89	0x01	0x49	0x46	0x30	0x33	0x2D	0x30	0x30	0x35	0x0A
ACK	PJ	Individual : 1	'I'	'F'	'0'	'3'	'_'	'0'	'0'	'5'	End

By the above exchange, it can be confirmed that the Software version is "03.005".

LAN setup [Lan Setup]

Used to setup LAN configuration.

Command code

Table 4-65 LAN SETUP CMD

HEX		ASCII		Function
0x4C	0x53	'L'	'S'	LAN setup [Lan Setup]

Parameter1

Data length: No regulation

Sub command table (Mandatory command only)

Table 4-66 LAN SETUP CMD SUB

HEX		ASCII		Function	Last memory	Operation	Reference
0x44	0x53	'D'	'S'	DHCP Client setting	Yes	✓	✓
0x49	0x50	'I'	'P'	IP Address setting	Yes	✓ (When 'DHCP Client' is Off.)	✓
0x53	0x4D	'S'	'M'	Subnet Mask setting	Yes	✓ (When 'DHCP Client' is Off.)	✓
0x44	0x47	'D'	'G'	Default Gateway setting	Yes	✓ (When 'DHCP Client' is Off.)	✓
0x4D	0x41	'M'	'A'	MAC Address setting	Yes	-	✓
0x52	0x53	'R'	'S'	Network reboot	No	✓	-
0x50	0x54	'P'	'T'	Port setting	Yes	✓	✓

- ♦ It consists of "Sub command" + "setting". Sub command consists of ASCII character 2 bytes.

Parameter2

Sub command parameters are as follows.

Parameters when Sub command is [0x44,0x53]: Data length 1

Table 4-67 DHCP Client

HEX	ASCII	Operation
0x30	'0'	Off(Static)
0x31	'1'	On

Parameters when Sub command is [0x49,0x50] [0x53,0x4D] [0x44,0x47]: Data length 8

Parameters when Sub command is [0x4D,0x41]: Data length 12

Parameters when Sub command is [0x52,0x53]: Data length 1

Table 4-68 NETWORK RESTART

HEX	ASCII	Operation
0x31	'1'	Network Restart

Parameters when Sub command is [0x50,0x54]: Data length 4

4.10.9 Operation

Use the command as shown in the following examples.

(Example1) DHCP Client setting

Purpose: To set DHCP Client to On.

(1) Transmit the data from the external controller to the projector as follows.

1: External controller →								
0x21	0x89	0x01	0x4C	0x53	0x44	0x53	0x31	0x0A
!(Operation)	PJ	Individual : 1	'L'	'S'	'D'	'S'	On	End

(2) If the projector receives the data (1) above and the command receipt is normal, an ACK is returned from the projector as follows.

2: ←Projector					
0x06	0x89	0x01	0x4C	0x53	0x0A
ACK	PJ	Individual : 1	'L'	'S'	End

(3) The projector set DHCP Client to On.

(Example2) IP Address setting

Purpose: To set IP Address to 192.168.1.10.

(1) Transmit the data from the external controller to the projector as follows.

1: External controller →															
0x21	0x89	0x01	0x4C	0x53	0x49	0x50	0x43	0x30	0x41	0x38	0x30	0x31	0x30	0x41	0x0A
!(Operation)	PJ	Individual : 1	'L'	'S'	'I'	'P'	192(=0xC0)	168(=0xA8)	1(=0x01)	10(=0x0A)					End

(2) If the projector receives the data (1) above and the command receipt is normal, an ACK is returned from the projector as follows.

2: ←Projector					
0x06	0x89	0x01	0x4C	0x53	0x0A
ACK	PJ	Individual : 1	'L'	'S'	End

(3) The projector saves "192.168.1.10." to IP Address. (Valid after network reboot)

(Example3) Network reboot

To reboot Network

(1) Transmit the data from the external controller to the projector as follows.

1: External controller →								
0x21	0x89	0x01	0x4C	0x53	0x52	0x53	0x31	0x0A
!(Operation)	PJ	Individual : 1	'L'	'S'	'R'	'S'	Execute	End

(2) If the projector receives the data (1) above and the command receipt is normal, an ACK is returned from the projector as follows.

2: ←Projector					
0x06	0x89	0x01	0x4C	0x53	0x0A
ACK	PJ	Individual : 1	'L'	'S'	End

(3) The projector reboots the Network.

(Example4) Port setting

Purpose: To set the Port to 10000(=0x2710).

(1) Transmit the data from the external controller to the projector as follows.

1: External controller →											
0x21	0x89	0x01	0x4C	0x53	0x50	0x54	0x32	0x37	0x31	0x30	0x0A
'!(Operation)	PJ	Individual : 1	'L'	'S'	'P'	'T'	10000(=0x2710)				End

(2) If the projector receives the data (1) above and the command receipt is normal, an ACK is returned from the projector as follows.

2: ← Projector					
0x06	0x89	0x01	0x4C	0x53	0x0A
ACK	PJ	Individual : 1	'L'	'S'	End

(3) The projector saves 10000 to the Port. (No matter what the Network reboot)

4.10.10 Reference

Use the command as shown in the following examples.

(Example1) DHCP Client confirmation

Purpose: To confirm DHCP Client.

(1) Transmit the data from the external controller to the projector as follows.

1: External controller →							
0x3F	0x89	0x01	0x4C	0x53	0x44	0x53	0x0A
'?(Reference)	PJ	Individual : 1	'L'	'S'	'D'	'S'	End

(2) If the projector receives the data (1) above and the command receipt is normal, an ACK is returned from the projector as follows.

2: ← Projector					
0x06	0x89	0x01	0x4C	0x53	0x0A
ACK	PJ	Individual : 1	'L'	'S'	End

(3) The projector transmits DHCP Client to the external controller.

3: ← Projector						
0x40	0x89	0x01	0x4C	0x53	0x30	0x0A
'@(Response)	PJ	Individual : 1	'L'	'S'	Off	End

By the exchange above, it can be confirmed that the projector DHCP Client is set to Off.

(Example2) MAC Address confirmation

Purpose: To confirm the current MAC Address.

(1) Transmit the data from the external controller to the projector as follows.

1: External controller →							
0x3F	0x89	0x01	0x4C	0x53	0x4D	0x41	0x0A
'?(Reference)	PJ	Individual : 1	'L'	'S'	'M'	'A'	End

(2) If the projector receives the data (1) above and the command receipt is normal, an ACK is returned from the projector as follows.

2: ← Projector					
0x06	0x89	0x01	0x4C	0x53	0x0A
ACK	PJ	Individual : 1	'L'	'S'	End

(3) The projector transmits MAC Address to the external controller.

3: ← Projector				
0x40	0x89	0x01	0x4C	0x53
'@(Response)	PJ	Individual : 1	'L'	'S'



0x30	0x30	0x38	0x30	0x38	0x38	0x31	0x32	0x33	0x34	0x35	0x56	0x0A
00		80		88		12		34		56		End

By the above exchange, it can be confirmed that the projector's MAC Address is set to "00:80:88:12:34:56".

(Example3) Port confirmation

Purpose: To confirm the current Port.

(1) Transmit the data from the external controller to the projector as follows.

1: External controller →							
0x3F	0x89	0x01	0x4C	0x53	0x50	0x54	0x0A
'?(Reference)	PJ	Individual : 1	'L'	'S'	'P'	'T'	End

(2) If the projector receives the data (1) above and the command receipt is normal, an ACK is returned from the projector as follows.

2: ← Projector					
0x06	0x89	0x01	0x4C	0x53	0x0A
ACK	PJ	Individual : 1	'L'	'S'	End

(3) The projector transmits Port to the external controller.

3: ← Projector									
0x40	0x89	0x01	0x4C	0x53	0x35	0x30	0x34	0x41	0x0A
'@(Response)	PJ	Individual : 1	'L'	'S'	20554(=504A)				End

By the above exchange, it can be confirmed that the projector's port is set to 20554(=504A).

End of specification