

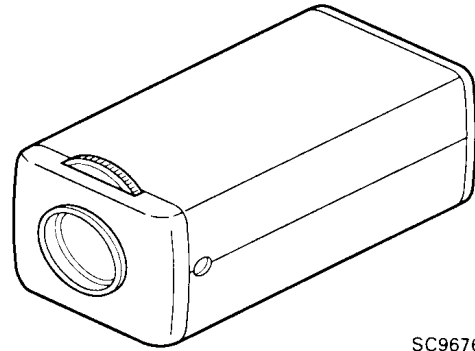

**COLOUR VIDEO CAMERA
FARB-VIDEOKAMERA
CAMERA VIDEO COULEUR**

**TK-C1380
TK-C1381**

**INSTRUCTIONS
BEDIENUNGSANLEITUNG
MANUEL D'INSTRUCTIONS**



SC96769 : TK-C1380U
SC96771 : TK-C1380E
 : TK-C1381EG

Thank you for purchasing the TK-C1380 / TK-C1381 colour video camera.

**WARNING:
TO PREVENT FIRE OR SHOCK HAZARD, DO NOT
EXPOSE THIS UNIT TO RAIN OR MOISTURE.**

Due to design modification, data given in this instruction book are subject to possible change without prior notice.

**WARNING-THIS APPLIANCE MUST
BE EARTHED
IMPORTANT**

The wires in this mains lead are coloured in accordance with the following code :

GREEN-AND-YELLOW : EARTH
BLUE : NEUTRAL
BROWN : LIVE

As the colours of the wires in the mains lead of this apparatus may not correspond with the coloured markings identifying the terminals in your plug, proceed as follows. The wire which is coloured GREEN-AND-YELLOW must be connected to the terminal in the plug which is marked with the letter E or by the safety earth symbol \perp or coloured GREEN or GREEN-AND-YELLOW.

The wire which is coloured BLUE must be connected to the terminal which is marked with the letter N or coloured BLACK. The wire which is coloured BROWN must be connected to the terminal which is marked with the letter L or coloured RED.

Contents

	Page
Features	2
Precautions	2
Controls, connectors and indicators	3
Set-up functions	5
Connection	13
Lens	14
How to use the ferrite core	17
Specifications	18

- Always make a prior test recording to help optimise the final recording.
- JVC does not assume any responsibility for failures to make recordings due to troubles with the video camera, VCR or tape cassette.

Features

- High-quality picture provided by the 1/2-inch, 410, 000-pixel (380,000 effective pixel) : NTSC, 470,000-pixel (440,000 effective pixel) : PAL high-performance design CCD with 470 TV line : NTSC, 460 TV line : PAL horizontal resolution and 0.95 lx (25%, F1.2) minimum object illumination.
- Backlight compensation (BLC) detecting areas can be selected from 4 fixed patterns as well as from two user-selectable patterns.
- Highlight inverter (HLI) function makes the picture around the position of a highlight easier to see.
- Lens mount switching mechanism makes it possible to use either a C-mount lens or CS-mount lens.
- Menu set-up system eliminates the need of setting operations using switches and controls.

Precautions

- Avoid installing the unit in following locations.
 - Places exposed to rain or moisture
 - Places with an ambient temperature outside the range of -10 to 50°C (operation) or from 0 to 40°C (recommended).
 - Places subject to excessive dust or to oil or gas.
- When this unit is used with AGC ON, an image recorded in a dark place may look noisy due to the automatic boost in sensitivity. This is not a malfunction.
- When this unit is used with the AUTO white balance control, the recorded colours may differ slightly from the actual colours due to the operation of the automatic-tracking white balance control circuit. This is not a malfunction.
- When a bright object (such as a lamp) is shot, a white, comet-tail phenomenon may be observed above and below the bright object on the screen. This is a phenomenon (called smear) inherent in CCD image pickup devices and is not a malfunction.

- The electronic shutter speed of this unit has been set to 1/50 second at the factory. If you use this unit under fluorescent lamps in an area with the local power frequency of 60 Hz, switch the shutter speed to 1/120 sec. (The sensitivity will be degraded slightly at 1/120 sec.)
- Lens aperture will be open when the electronic shutter is operated on AUTO mode with an auto iris lens in use. To avoid this, set the shutter to any mode other than AUTO or use a manual (fixed) iris lens.
- When the electronic shutter is set to the AUTO mode while this unit is used under fluorescent lamp illumination, flickering may be observed in the picture. This is a phenomenon caused by the relationship between the light's power frequency and shutter speed, and is not a malfunction.
- When using a zoom lens, it is recommended to run the camera with your zoom lens attached and check the backfocus before camera installation. The same applies to lens attached and check the backfocus before camera installation. The same applies to lens level adjustment. (See the lens instruction manual for details.)
- Be sure to attach the provided ferrite core to the lens cable or power cable to be connected with this camera to minimize unnecessary radiation.
- Avoid installing in places where there is radiation. This could damage CCD and other components and cause a malfunction.
- Avoid installing in places where there are strong electromagnetic waves or magnetism. The picture could be distorted.
- Avoid installing in places where the camera would be subject to strong vibrations. This could damage components and degrade the picture.

2

Controls, connectors and indicators

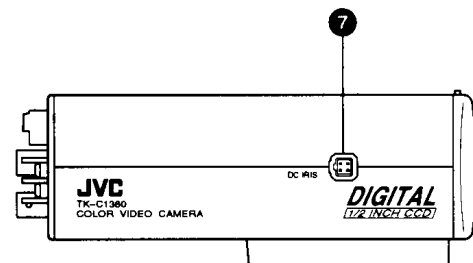
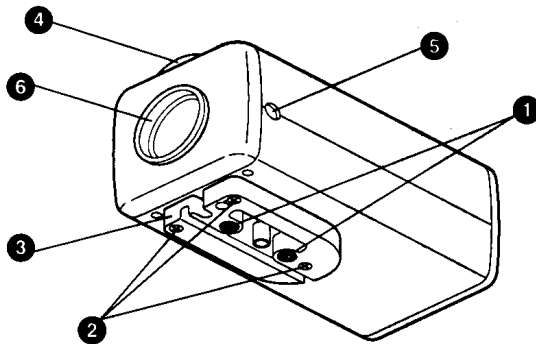

- 1 Camera mounting holes (1/4-inch)**
Use one of these threaded holes when mounting the camera on a mount or turret. Two threaded holes are provided on the front and rear and can be selected according to the circumstance.
- 2 Camera mounting bracket locking screws (x 3 : M2.6 x 5mm)**
Do not use any screw longer than 5 mm.
- 3 Camera mounting bracket**
The bracket has been attached on the bottom of the camera before shipment. It can also be attached on the top according to the circumstance.
To re-attach the bracket use the threaded holes at the top, with the 3 camera mounting bracket locking screws **2**.
- 4 Backfocus adjustment ring**
This ring both allows the adjustment of the backfocus to and

switch as the lens mounting method between C and CS. Loosen the BF LOCK screw **5** by turning it counterclockwise before turning this ring, and be sure to secure screw **5** by turning it clockwise after turning this ring. The TK-C1380 / TK-C1381 has been adjusted to the optimum position for the C mount before shipment.

- 5 [BF LOCK] Backfocus locking screw**
This screw locks the backfocus adjustment mechanism.
- 6 Lens mount**
The lens mount is compatible with C-mount lenses (1/2 and 2/3 inch) and CS-mount lenses (1/2 inch).
- 7 [DC IRIS] DC iris connector**
Connect to an auto-iris lens which does not incorporate an EE amplifier. (See "Lens" on page 14.)

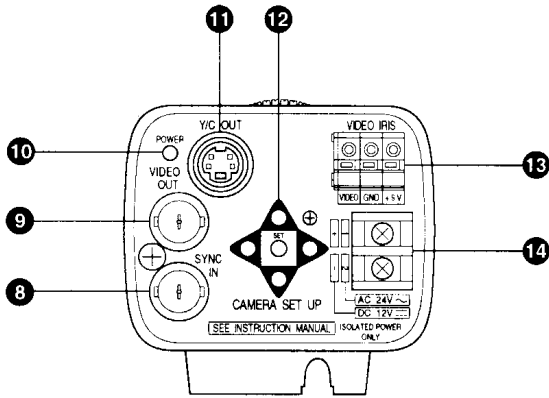

TK-C1380

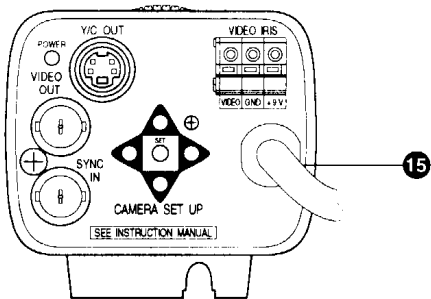

TK-C1381

8 [SYNC IN] Sync signal input connector

This BNC connector accepts the input of an external sync signal such as a composite video (VBS) or black burst (BB) signal. When a sync signal is input into this connector, the camera operation is automatically synchronized with the external sync signal.

The 75-ohm termination of this connector can be switched on/off on the menu screen as required. (For details, see "TERM. [75-ohm termination setting]" on page 6.)

9 [VIDEO OUT] Video signal output connector

This BNC connector outputs a composite video signal. Connect this to the video input connector of a video monitor, switcher, etc.

10 [POWER] Power indicator lamp

This lights when power is supplied to the camera.

11 [Y/C OUT] Y/C output connector

This 4-pin connector outputs the luminance and chrominance signal.

- Pin configuration of Y/C OUT connector

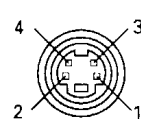

Pin No.	Signal
1	GND
2	GND
3	Luminance (Y, 1 V(p-p), 75-ohm)
4	Chrominance (C, 0.286 V(p-p), 75-ohm), NTSC Chrominance (C, 0.3 V(p-p), 75-ohm), PAL

Controls, connectors and indicators (continued)

12 [CAMERA SET UP] Camera set-up screen operation buttons

These buttons are used in the set-up operations. For details, see "Set-up functions" from page 5.

13 [VIDEO IRIS] Video iris connector

Connect to an auto-iris lens incorporating an EE amplifier. (See "Lens" on page 14.)

14 [DC12V/AC24V] Power input connector (TK-C1380 only)

Connect a DC 12 V ± 10% or AC 24 V ± 10%, 50/60 Hz power supply.

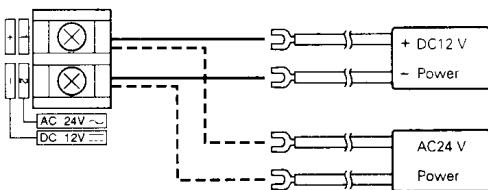

15 Power cable (for TK-C1381 only)

Connect to the commercial AC 230V outlet.

Caution

When you use this camera, the socket-outlet shall be installed near the equipment so as to disconnect easily.

Setup functions

■ CAMERA SETUP screen

The camera is adjusted using the CAMERA SETUP screen.

Press the SET button to display the CAMERA SETUP screen on the monitor.

CAMERA SETUP screen

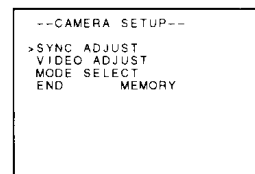

Operation buttons

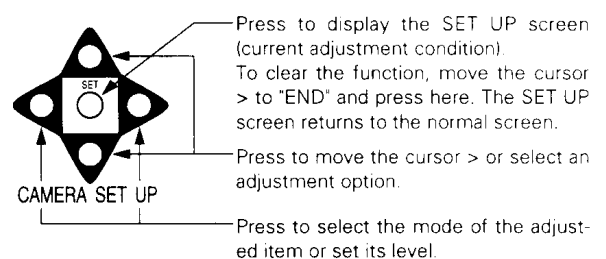

● SYNC ADJUST menu

For settings related to the sync signals.

```
--SYNC ADJUST--
>TERM.      ON
H PHASE    25
SC COARSE  1
SC FINE    128
LINE LOCK  OFF
V COARSE   1
V FINE     128
END
```

1. Move the cursor to "SYNC ADJUST".
2. Press the SET button to display the SYNC ADJUST menu.
(See pages 6 and 7 for the operating procedure.)

● VIDEO ADJUST menu

For settings related to the video signal.

```
--VIDEO ADJUST--
>IRIS      0
COLOUR     0
PEDESTAL  0
ENHANCE    0
HUE        0
END
```

1. Move the cursor to "VIDEO ADJUST".
2. Press the SET button to display the VIDEO ADJUST menu.
(See pages 7 and 8 for the operating procedure.)

● MODE SELECT menu

For settings related to the camera functions.

```
--MODE SELECT--
>ID        OFF
AGC GAIN   18dB
SUPER AGC  OFF
SHUTTER    MANU ( )
BLC        OFF
AV PK      8:2
W BAL      AUTO
HLI        OFF
END
```

1. Move the cursor to "MODE SELECT".
2. Press the SET button to display the MODE SELECT menu.
(See pages 8 to 12 for the operating procedure.)

SYNC ADJUST menu

■ TERM. [75-ohm termination setting]

```
--SYNC ADJUST--
>TERM.      ON
H PHASE    25
SC COARSE  1
SC FINE    128
LINE LOCK  OFF
V COARSE   1
V FINE     128
END
```

Set according to whether the signal input into the sync signal input terminal **8** is to be terminated with 75 ohms or not.
ON : Terminated with 75 ohms
OFF : Open
Initial set ON.

Note:

The terminal is open when the power is OFF.

■ H PHASE [Horizontal phase adjustment]

```
--SYNC ADJUST--
>TERM.      ON
H PHASE    25
SC COARSE  1
SC FINE    128
LINE LOCK  OFF
V COARSE   1
V FINE     128
END
```

Adjustment of the H phase in gen-lock operation. Adjust with reference to another camera (or system).
Variable range : 0 to 50.
Initial set : 25.

■ SC COARSE [Sub-carrier phase coarse adjustment]

```
--SYNC ADJUST--
>TERM.      ON
H PHASE    25
SC COARSE  1
SC FINE    128
LINE LOCK  OFF
V COARSE   1
V FINE     128
END
```

Coarse adjustment of the SC phase in gen-lock operation. The SC phase can be varied by up to 90° in each direction. Adjust with reference to another camera (or system) and together with the SC FINE adjustment.
Variable range : 1, 2, 3, 4.
Initial set : 1.

Note:

Only the \blacktriangleright button is effective. The \blacktriangleleft button does not operate.

Setup functions (continued)

■ SC FINE [Sub-carrier phase fine adjustment]

```
--SYNC ADJUST--
TERM.      ON
H PHASE    25
SC COARSE  1
>SC FINE   128
LINE LOCK  OFF
V COARSE   1
V FINE     128
END
```

Fine adjustment of the SC phase in gen-lock operation.
Variation range : 0 to 255.
Initial set : 128.

Notes:

Adjust H PHASE only after adjusting SC COARSE and SC FINE.

■ LINE LOCK [Line lock setting]

```
--SYNC ADJUST--
TERM.      ON
H PHASE    25
SC COARSE  1
SC FINE    128
>LINE LOCK OFF
V COARSE   1
V FINE     128
END
```

Setting when the vertical sync signal of the camera is to be locked with the AC power frequency.
ON : LL mode is activated.
OFF : LL mode is unactivated.
Set to OFF when using INT (internal sync) or EXT (external sync).
Initial set : OFF.

Notes:

- Do not apply an external sync signal in the LL mode.
- The display will be switched over between ON and OFF, however, the LL function is only available with the power frequency of 60 Hz.

■ V COARSE [Vertical phase coarse adjustment]

```
--SYNC ADJUST--
TERM.      ON
H PHASE    25
SC COARSE  1
SC FINE    128
LINE LOCK  OFF
>V COARSE  1
V FINE     128
END
```

Adjustment to align the vertical phase with another camera operating in the line lock (LL) mode. The phase can be varied by up to 180° in courses 1 and 2. Adjust together with the V FINE adjustment.
Variable range : 1, 2.
Initial set : 1.

■ V FINE [Vertical phase fine adjustment]

```
--SYNC ADJUST--
TERM.      ON
H PHASE    25
SC COARSE  1
SC FINE    128
LINE LOCK  OFF
V COARSE   1
>V FINE    128
END
```

Fine adjustment of the vertical phase in the LL mode.
Variable range : 0 to 255.
Initial set : 128.

VIDEO ADJUST menu

■ IRIS [Iris level]

```
--VIDEO ADJUST--
>IRIS      0
COLOUR     0
PEDESTAL  0
ENHANCE    0
HUE        0
END
```

Adjustment of the luminance level of the video signal.
Variable range : - 5 to 5.
Initial set : 0.
• IRIS OPEN Increase the number (\blacktriangleright)
• IRIS CLOSE Decrease the number (\blacktriangleleft)

Note:

When using a video-iris lens or DC-iris lens or when SHUTTER is set to AUTO, set the AGC GAIN of MODE SELECT menu to 0 before starting iris level adjustment.

■ COLOUR [Colour level]

```
--VIDEO ADJUST--
IRIS          0
>COLOUR      0
PEDESTAL     0
ENHANCE      0
HUE          0
END
```

Adjustment of the colour level of the video signal.
 Variable range : - 5 to 5.
 Initial set : 0.

- To increase colour saturation Increase the number (▶).
- To decrease colour saturation Decrease the number (◀).

■ PEDESTAL [Pedestal level]

```
--VIDEO ADJUST--
IRIS          0
COLOUR        0
>PEDESTAL    0
ENHANCE      0
HUE          0
END
```

Adjustment of the pedestal level of the video signal.
 Variable range : - 5 to 5.
 Initial set : 0.

- To brighten picture Increase the number (▶).
- To darken picture Decrease the number (◀).

■ ENHANCE [Enhancement level]

```
--VIDEO ADJUST--
IRIS          0
COLOUR        0
PEDESTAL     0
>ENHANCE     0
HUE          0
END
```

Adjustment of the aperture control level of the video signal.
 Variable range : - 5 to 5.
 Initial set : 0.

- To sharpen the picture (by enhancing the aperture control and contour level) Increase the number (▶).
- To soften the picture (by attenuating the aperture control and contour level) Decrease the number (◀).

■ HUE [Hue adjust]

```
--VIDEO ADJUST--
IRIS          0
COLOUR        0
PEDESTAL     0
ENHANCE      0
>HUE         0
END
```

Adjustment of the hue of the video signal.
 Variable range: - 5 to 5. Initial set: 0.

- To make yellowish Increase the number (▶).
- To make reddish Decrease the number (◀).

MODE SELECT menu

■ ID [Camera ID name/number]

```
--MODE SELECT--
>ID           OFF
AGC GAIN     18dB
SUPER AGC    OFF
SHUTTER      MANU( )
BLC          OFF
Av Pk       8.2
W BAL       AUTO
HLI         OFF
END
```

The camera ID can be up to 24 characters.
 ON : The camera ID is displayed.
 OFF : The camera ID is not displayed.
 EDIT : The camera ID can be set.

Monitor screen when "ON" is selected (initial setup)

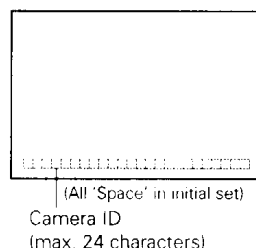

Monitor screen when "EDIT" is selected

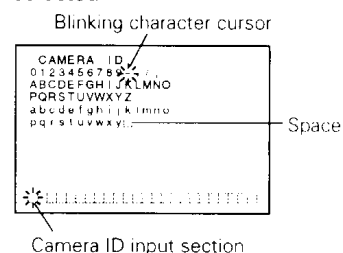

Setup functions (continued)

Setting method

1. Select "EDIT" with the ◀ or ▶ button and press the SET button. The CAMERA ID screen appears, with the character cursor and the first character in the input section blinking.

Notes:

The cursor ">" of MODE SELECT menu cannot be moved when ID is set at EDIT.

2. Select a character with the ◀ or ▶ button.
 (Enter a space in positions where no character is to be input.)
3. Press the ▽ button to set the character. Then the input section for the next character starts to blink.
 (Press the △ button to return to the previous character.)
4. After all characters have been input by repeating steps 2 and 3, press the SET button. The CAMERA SETUP screen is displayed again.
5. ID appears when set to ON.

■ AGC GAIN [Automatic Gain Control]

```
--MODE SELECT--
ID           OFF
>AGC GAIN    18dB
SUPER AGC    OFF
SHUTTER      MANU( )
BLC          OFF
Av Pk       8.2
W BAL       AUTO
HLI         OFF
END
```

Setting the max. gain of the AGC (Automatic Gain Control).
 Variable range: 0, 9 and 18 dB.
 Initial set: 18 dB.

■ SUPER AGC [High-sensitivity automatic gain control]

```
--MODE SELECT--
ID           OFF
>AGC GAIN    18dB
SUPER AGC    OFF
SHUTTER      MANU( )
BLC          OFF
Av Pk       8.2
W BAL       AUTO
HLI         OFF
END
```

Use this function if the picture is not bright enough when AGC GAIN is set to 18 dB.
 ON : The gain is further increased.
 OFF : The gain is not increased.
 Initial set : OFF.

Notes:

- When AGC GAIN is set to 9 or 18 dB or when SUPER AGC is set to ON, dark parts of the picture may look noisy. This is because sensitivity increased and it is not a malfunction.
- With SUPER AGC set to ON, the level reaches 18 dB even with AGC GAIN at 0 or 9 dB. AGC GAIN display does not change however.
- The camera ID level can be adjusted by turning SUPER AGC on and off.
- The response of the SUPER AGC may be retarded against the acute level changes.

■ SHUTTER [Electronic shutter]

```
--MODE SELECT--
ID           OFF
AGC GAIN     18dB
SUPER AGC    OFF
>SHUTTER     MANU( )
BLC          OFF
Av Pk       8.2
W BAL       AUTO
HLI         OFF
END
```

Set according to whether the electronic shutter is to be switched manually or automatically.

- MANUAL : 1/60s : NTSC, 1/50s : PAL,
 1/100s : NTSC, 1/120s : PAL,
 1/250s, 1/500s, 1/1000s,
 1/2000s, 1/4000s, 1/10000s
- AUTO : 1/50 - 1/100000s : PAL
 Variable range : 1/60 - 1/100000 : NTSC
 Initial set : MANU (1/50) : NTSC
 MANU (1/60) : PAL

<Setting in MANUAL mode>

1. Press SET button in MANU (1/60 : NTSC, 1/50 : PAL) mode, and () are removed to allow setting.
2. Change the shutter speed with ◀ or ▶ button.
3. Press SET button again, and () comes out to finish shutter speed setting.

If the AUTO mode or a high-speed shutter mode is selected under fluorescent lighting, the picture could flickering or the white balance could be un-stable.

In such a case, the flickering and white balance variation can be improved by setting the shutter speed to 1/100 (1/120) in an area where the local power supply frequency is 50 (60) Hz or to 1/60 (1/50) in an area where it is 60 (50) Hz.

Note:

When shutter speed is higher, goes to worse the smear which is a phenomenon inherent to CCDs.

■ BLC [Back light compensation]

```
--MODE SELECT--
ID          OFF
AGC GAIN    18dB
SUPER AGC   OFF
SHUTTER     MANU( )
>BLC        OFF
AV:PK       8:2
W.BAL       AUTO
HLI         OFF
END
```

Set when there is a strong light source in the background. The BLC provides four fixed areas and 2 user-set areas.

Variation values : OFF, AREA1, AREA2, AREA3, AREA4, EDIT1, EDIT2.

Factory setup : OFF.

1. Select AREA with ◀▶ buttons.
2. Press the SET button to show "detecting". Set the area as required.
3. When setting is done, press the SET button again and MODE SELECT screen will resume.

Fixed area

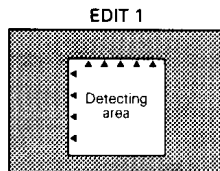
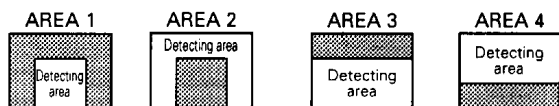

Press the SET button

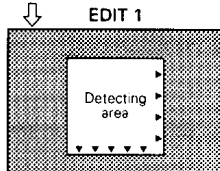

EDIT 2

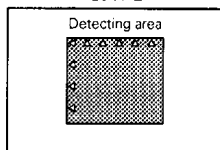

Press the SET button

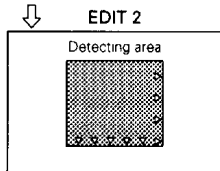

User set area

EDIT1

Use this area when the metered area is located at the center of the field of view.

- ◀ button Move the detecting area to the left.
- ▶ button Move the detecting area upwards.
- ▷ button Move the detecting area to the right.
- ▽ button Move the detecting area downwards.

EDIT2

Use this area when the metered area is located at the edge of the screen.

- ◀ button ... Move the undetecting area to the left.
- ▶ button ... Move the undetecting area upwards.
- ▷ button ... Move the undetecting area to the right.
- ▽ button ... Move the undetecting area downwards.

Note:

The detecting areas displayed with AREA1 to 4 and EDIT1 and 2 are for reference and may be different from the actual detecting areas.

Setup functions (continued)

■ Av:Pk [Average value: Peak value]

```
--MODE SELECT--
ID          OFF
AGC GAIN    18dB
SUPER AGC   OFF
SHUTTER     MANU( )
>BLC        OFF
AV:PK       8:2
W.BAL       AUTO
HLI         OFF
END
```

Sets the ratio between the average value (Av) and peak value (Pk) in exposure detection.

Use this setting when a video-iris lens or DC-iris lens is used or when SHUTTER is set to AUTO.

Variation range : 5:5, 6:4, 7:3, 8:2, 9:1, 10:0.
Initial set : 8:2.

Av value effect : Increase the Av value when part other than the high light part are dark and look washed out. This setting is used when there is artificial lighting in a dark room.

(Example: 10:0)

Pk value effect : Increase the Pk value when halation tends to be observed in the highlight part of the picture. (Example: 5:5)

■ W.BAL [White balance]

```
--MODE SELECT--
ID          OFF
AGC GAIN    18dB
SUPER AGC   OFF
SHUTTER     MANU( )
>BLC        OFF
AV:PK       8:2
>W.BAL      AUTO
HLI         OFF
END
```

Automatic or manual setting of the white balance in the color temperature range of 2500K to 7000K.

AUTO : Automatic color temperature tracking mode.

MANUAL : Manual adjustment mode.
Initial set : AUTO.

MANUAL adjustment screen

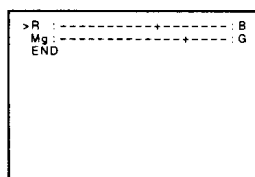

1. Adjustment screen appears when pressing the SET button on the "MANUAL" mode.

2. Adjust with ◀ or ▶ button.
◀ button is used for adjustment to red (magenta, whereupon + is moved to R (Mg)).

▶ button is used for adjustment to blue (green, whereupon + is moved to B (G)).

3. Switching between R/B and Mg/G can be performed with ▲ or ▼ button.

Note:

In AUTO mode, the optimum white balance may not be obtained when the light source has a color temperature outside the adjustment range.

In such a case, set W.BAL to the MANUAL mode.

■ HLI [Highlight inverter]

```
--MODE SELECT--
ID          OFF
AGC GAIN    18dB
SUPER AGC   OFF
SHUTTER     MANU( )
>BLC        OFF
AV:PK       8:2
>W.BAL      AUTO
>HLI        OFF
END
```

The HLI function inverts the highlight part of picture so that the parts around it can be seen more clearly.

Variable values : OFF, ON(1), ON(2), ON(3)

Initial set : OFF

ON is adjustable in three degrees. The smaller the number, the brighter the area to be blacked.

<How to set HLI>

1. Press ◀ or ▶ button, and OFF is changed to ON (1) to enter the HLI mode.
2. Press SET button to remove (), and ON1 is displayed to allow on-screen selection.
3. Monitoring the screen, select one of ON1, ON2 and ON3 with ◀ or ▶ button.
4. Press SET button again, and () comes out to finish setting.

■ To clear the setup functions

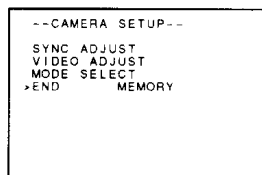

1. Move the cursor ">" to END.
2. Select END mode with ◀ or ▶ button.
MEMORY : Set value holds.
CLEAR : All the set values resume the values.
3. Press SET button to set the END mode, resuming the initial setting screen.

Notes:
ID (camera title) is not cleared with CLEAR.

Connection

■ System connection example

- Do not turn on the power of any component before all connections have been completed.
- Read the instruction manuals of the components to be connected carefully.

In case of TK-C 1380

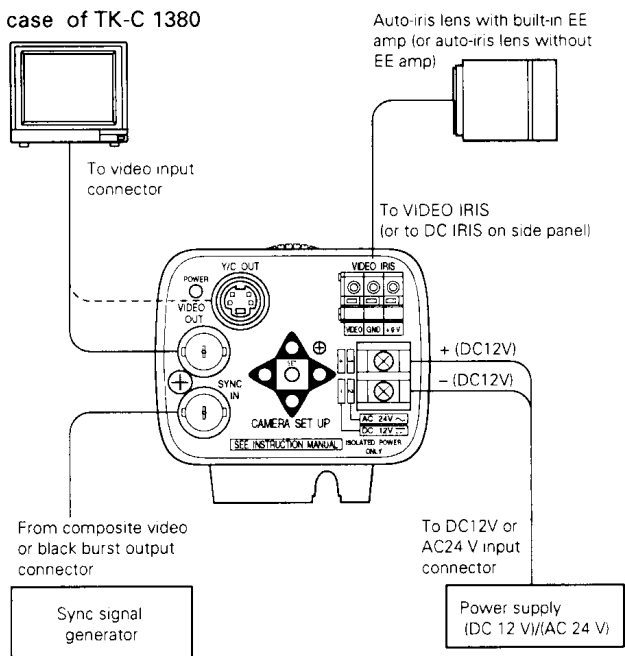

Genlock connection

With some systems, genlocking by applying an external sync input requires the horizontal phase (H PHASE) and/or color phase (SC COARSE) (in case the external sync signal is a composite video or black burst signal) to be adjusted.

Notes:

- Genlocking is not possible with a signal containing too much jitter, such as a VCR or videodisc playback signal.
- For details, consult JVC authorized dealer.

Caution

- Be sure to observe the correct +, - polarity when connecting a DC 12 V power input.
- The DC 12 V power should have a ripple voltage of no more than 50 mV.
- Never connect the DC 12 V and AC 24 V power inputs simultaneously.
- Be sure to attach the provided ferrite core to the lens cable or power cable to be connected with this camera. (see page 17 for details)

Lens

■ Lens mounting procedure

1. Check the mounting of your lens before attaching it to the camera. The camera has been set for a C mount before shipment (Figure 1-1). When mounting a CS-mount lens, loosen the BF LOCK screw (5 on page 4) by turning it counter-clockwise and turn the backfocus adjustment ring (4 on page 4) in the direction of the arrow in Figure 1-1 to switch the mounting method. (Figure 1-2 shows the camera set for a CS mount lens.)

Fig. 1

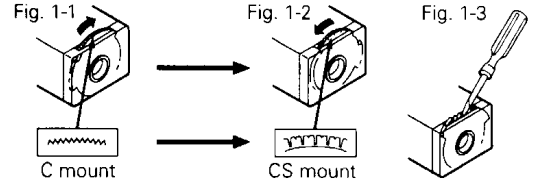

2. Mount the lens on the camera by turning the lens clockwise and adjust its position.
3. When an auto-iris lens is used, also connect the lens cable to the camera.
 - A If the lens does not incorporate an EE amp, connect the cable to the DC IRIS connector on the side panel (Figure 2-1).
 - B If the lens incorporates an EE amp, connect the cable to the VIDEO IRIS connector on the rear panel (Max 50mA).

Caution

- The ring cannot be turned by more than a certain amount with your finger. Use a thin object (screwdriver tip, etc.) to turn the ring (Figure 1-3).
- Distance L of the lens mounting section shown in the following illustration should comply with the condition shown in the following table. Never use a lens with a flange back distance L greater than, the one Specified in the chart below. As this will damage the inside of the camera or may make normal mounting impossible. Also, be careful not to attempt to mount a C-mount lens while the camera is set for a CS mount.

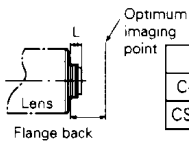

Lens	Flange back	Distance L
C-mount lens	17.526 mm	No more than 10 mm
CS-mount lens	12.5 mm	No more than 5.5 mm

Fig. 2

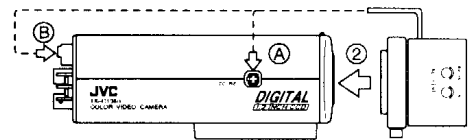

14

Lens (continued)

Fig. 2-1

Connector pin layout (DC IRIS) (External view of camera connector)

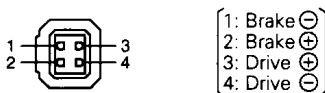

- After completing connections as shown in "Connection" on page 14, supply power to the camera, display a picture on the monitor and check the image.

Auto-iris lenses have generally been adjusted for the widest applicability before shipment, but readjustment may sometimes be necessary depending on the conditions of the objects to be shot and the lens combination. If the picture recorded using such a lens looks unnatural, readjust as shown below

- Auto-iris lens with built-in EE amp

• LEVEL adjustment

Monitor screen	LEVEL turning direction
To darken picture	Counterclockwise (toward L)
To brighten picture	Clockwise (toward H)

• ALC adjustment

This cannot be adjusted on the lens. The ALC should be adjusted as described in "Av : Pk [Average value : Peak Value]" on Page 11.

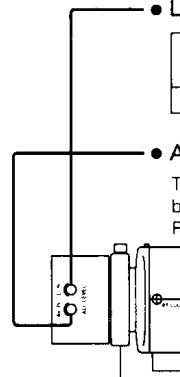

Auto-iris lens with built-in EE amp

Caution

Do not turn the LEVEL control too far towards "L" as this could cause the AGC of the camera to increase the gain, making the picture look rough.

- Auto-iris lens without EE amp
Re-adjust as described in "IRIS [Iris level]" on page 7.

■ Backfocus adjustment

The backfocus has been adjusted before shipment so that the widest range can be obtained with C-mount lenses, but readjustment is necessary when the lens mount is switched to the CS mount or a combination lens is used. When necessary, readjust the backfocus by the following procedure.

<When a fixed – focus lens is used>

Readjust the backfocus when the optimum focusing cannot be obtained by adjusting the focusing ring of the lens.

1. Loosen the BF LOCK screw by turning it counterclockwise with a screwdriver.
2. Optimize the focus by turning the backfocus adjustment ring.
3. Lock the BF LOCK screw by turning it clockwise.

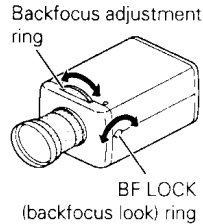

<When a zoom lens is used>

Readjust the backfocus when focusing is lost during zooming (from wide angle to telephoto).

1. Loosen the BF LOCK screw by turning it counterclockwise with a screwdriver.
2. Shoot a fine pattern of as dark as possible an object at a distance of more than 3 meters.
3. Set the zoom for telephoto and adjust the focus with the lens's focusing ring.
4. Set the zoom for wide angle and adjust the focus by turning the backfocus adjustment ring. (Refer to "When a fixed-focus lens is used" above.)
 - Repeat steps 3 and 4 a few times.
5. Lock the BF LOCK screw by turning it clockwise.

■ Fixing the lens cable

If the lens cable is too long and gets in the way, wrap the cable round the camera mounting bracket as shown below.

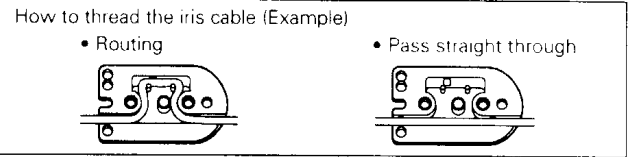

How to mount the camera on a tripod stand, fixing unit or pan / tilt unit.

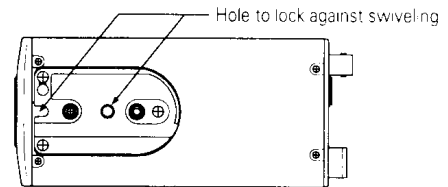

- Special precautions must be taken for ganging the camera on a wall or a ceiling. Consult with an installation professional without attempting at installation all by yourself.
- We are by no means liable for any dropping or other accident due to improper installation.

16

How to use the ferrite core

To retain electromagnetic compatibility, use the provided ferrite cores when connecting to the lens or the power source.

(TK-C1380)

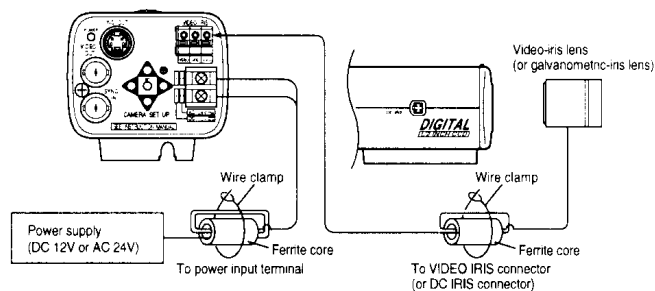

Notes:

- Install the ferrite cores within 50 mm of the camera-side connectors. (Fasten with the ferrite core with the wire clamp.)
- For lens connection : Pass the lens cable through the ferrite core twice and connect it to the camera.
- For power supply connection : Pass the power cable through the ferrite core three times and connect it to the camera.

(TK-C1381)

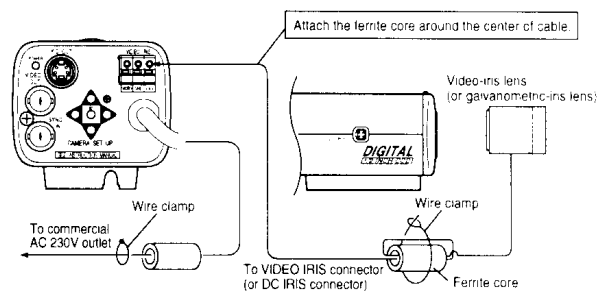

Notes:

- Install the ferrite cores within 50 mm of the camera-side connectors. (Fasten the ferrite core with the wire clamp.)
- For lens connection : Pass the lens cable through the ferrite core twice and connect it to the camera.
- Power cable : Pass the power cable through the ferrite core and connect to the AC 230V outlet.

Specifications

Image pickup device	: 1/2-inch, interline-transfer CCD
Effective pixels	: 380,000 pixels [768(H) × 494(V)] (NTSC) 440,000 pixels [752(H) × 582(V)] (PAL)
Sync systems	: Internal, external, power sync (60 Hz areas only) : NTSC (50 Hz areas only) : PAL
Scanning frequency	: 15.734 kHz (H), 59.94 Hz (V) : NTSC 15.625 kHz (H), 50.0 Hz (V) : PAL
Horizontal resolution	: 470 TV lines (H) : NTSC 460 TV lines (H) : PAL
Video S/N	: 48 dB
Minimum illumination	: 0.95 lx (25%, F1.2, AGC "ON")
Lens mount	: C/CS mount
Power supply	: AC 24 V 50/60 Hz or DC 12 V, (TK-C1380) AC 220 V to 240V, 50/60 Hz (TK-C1381)
Power consumption	: AC 24 V 50/60 Hz 380 mA, DC 12V 470 mA (TK-C1380) AC 230 V 50/60 Hz 60 mA (TK-C1381)
Ambient temperatures	: - 10 to 50°C (operation), 0 to 40°C

Dimensions (Unit: mm)

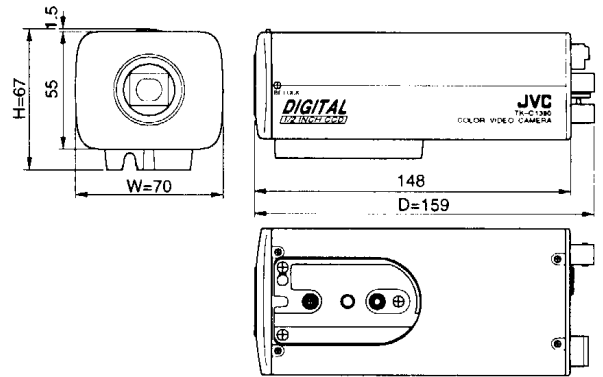

Design and specifications are subject to change without notice.

Weight	: (recommended) 740 g (TK-C1380), 870g (TK-C1381)
Accessories	: • 4-pin iris plug × 1 • 4-pin Y/C plug × 1 • Ferrite core × 2