



# Remote Production over the Internet - REMI.

The JVC *Connected CAM* camcorders feature built-in SRT encoders with LAN/Wi-Fi connectivity to provide broadcast-quality video over the Internet directly from the camera, no additional backpacks or encoders needed to send ISO feeds to the remote studio.

GY-HC550



GY-HC900

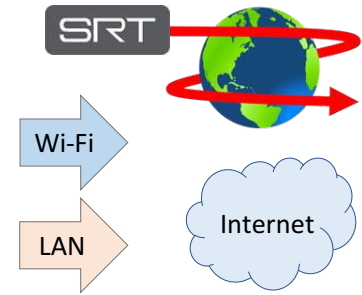

Model	Sensor	Lens	Recording	Video-over-IP	Protocols	Error Correction
GY-HC900	3 x 2/3" CMOS	B4 mount	10-bit 4:2:2	1080 60p up to 24 Mbps H.264	SRT RTMP/S UDP/RTP Zixi*	SRT SMPTE2022 Zixi*
GY-HC550	1" CMOS	20x / 40x (HD) Zoom				
GY-HC500						

\* Except GY-HC500

## Remote Production - REMI:

When the broadband Internet connection is available on location and at the studio, the workflow is simply connecting camera LAN to the router or using built-in camera Wi-Fi for wireless connectivity. The H.264 or HEVC\* encoded ISO feed from each camera can be sent directly to Newtek TriCaster, vMix, SRT Server, or BR-DE900 decoder using Secure Reliable Transport - the **SRT** protocol.

\* With optional module

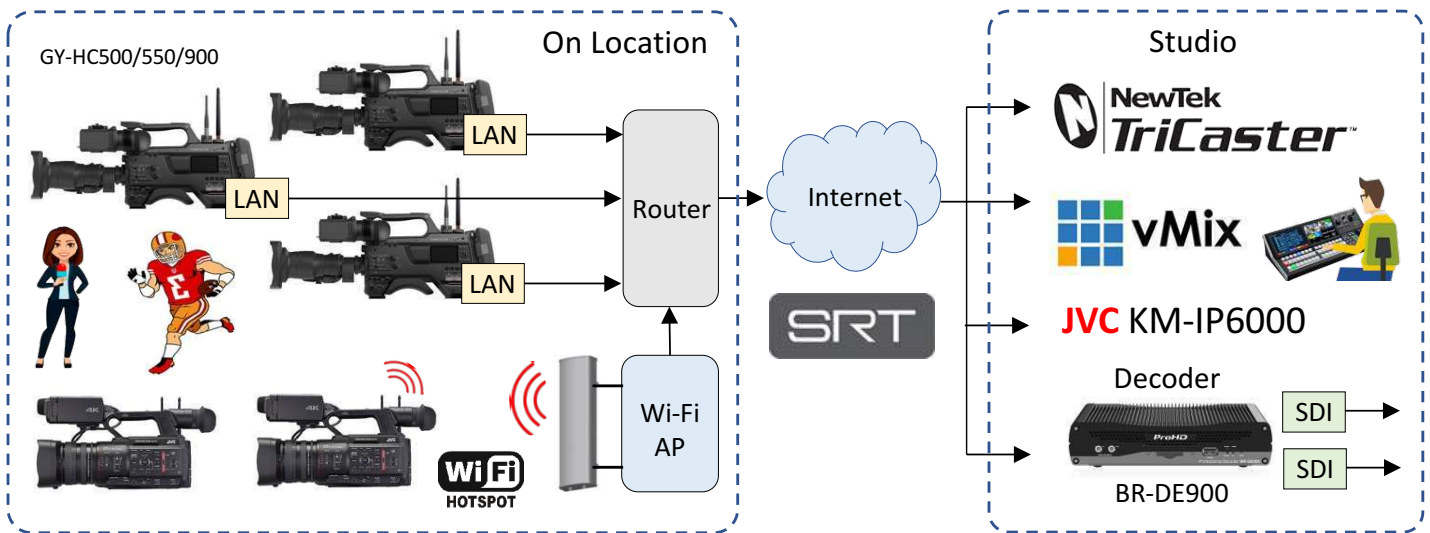

SRT protocol employs ARQ and FEC error correction and adaptive bitrate to compensate for occasional data loss, latency, and jitter when sending video over unpredictable networks.

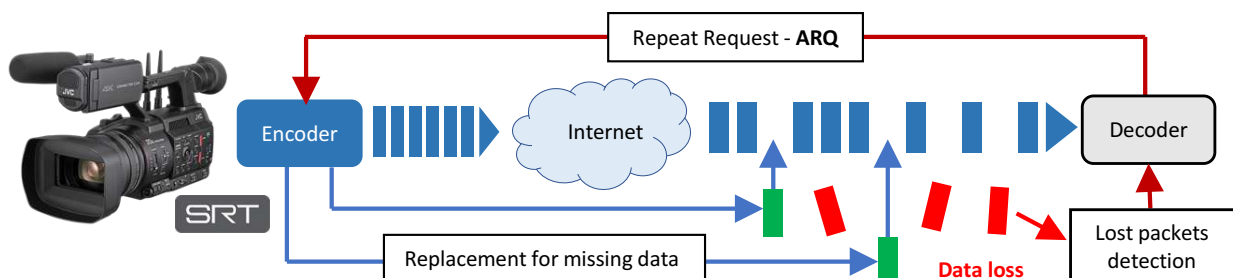

The Connected CAM camcorders feature a 10-bit 4:2:2 Recorder, Streaming Encoder, Return Video Decoder, IFB (Return Audio), and Remote Control (RCU) over the Internet via LAN, Wi-Fi, or LTE Hotspot. Simultaneous Recording, Streaming Video, and receiving Video Return is possible with independent control of these functions over IP via Chrome browser (no special software needed).

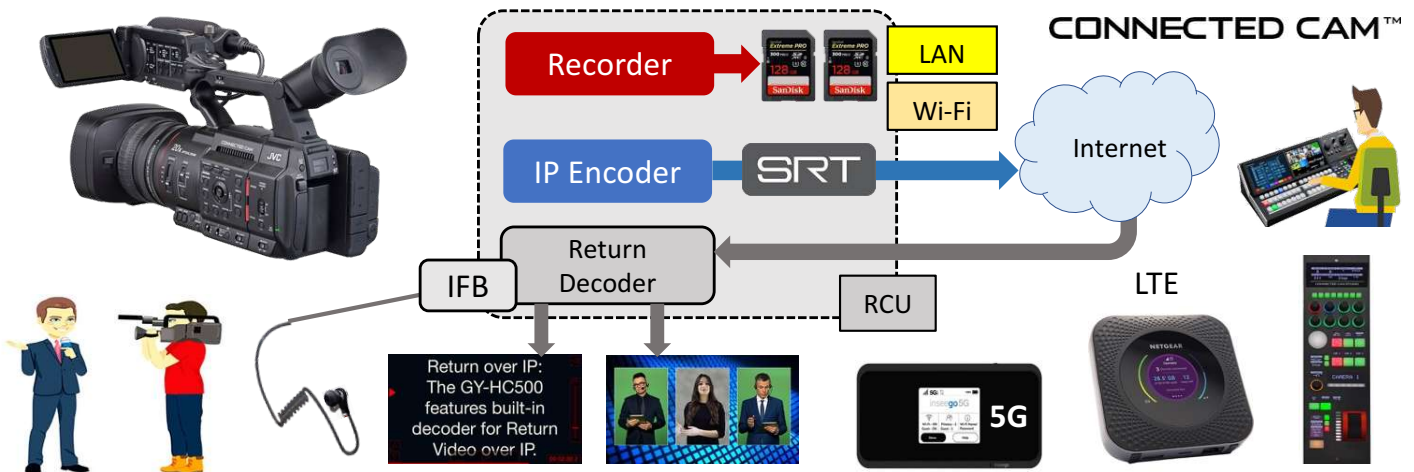

Setup on location is quick and simple: the camera can store 4 streaming destinations and return video (IFB) sources. With all settings pre-programmed, connecting to the Internet and pressing the "Online" button is all that is needed to start a contribution-quality video feed to the remote studio.

SRT protocol features real-time stream quality confirmation with the status displayed in the camera's LCD/EVF. When the receiver (decoder) detects the excessive data loss which cannot be corrected with the built-in error correction, the "LIVE" indicator will change color to notify the cameraman / talent that transmission quality may be compromised. Detailed stream quality data is available when pressing the "Status" button on the camera.

The Internet / Network connection status is also shown for instant connection confirmation.

Real-time Stream Quality Confirmation

Decoder

LIVE

LIVE

LIVE

Connection

Streaming

In Progress

Type	SRT
Uptime	10:11:57
Total	33450139
Recovered	1945871
Not Recovered	56
Latency	300 ms

## Bandwidth and Latency considerations.

When using multiple cameras on location it is necessary to provide sufficient bandwidth for multiple video streams. Upload Speed = 5-8 Mbps x N (amount of cameras). If bandwidth is limited, consider reducing resolution and frame rate. Most ISPs advertise the *download* speed, while the *upload* is important when sending live video. Test the upload speed with <https://testmy.net/upload>

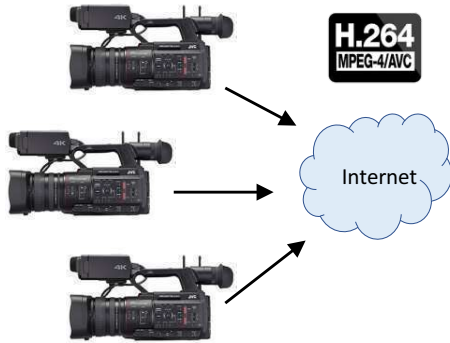

Resolution	Frame Rate	Bitrate, Mbps (per camera)				
		1.5	3	5	8	12
1920x1080	60p					
	60i					
	30p					
1280x720	60p					
	30p					

The ability of the SRT protocol to compensate for Internet data loss and high jitter is directly dependent on the *Latency Allowance*. Extra latency is needed to request the replacement data from the encoder (ARQ) and to buffer the stream to assure smooth video despite packet loss and jitter. It is recommended to set Latency = RTT x 3-6 (RTT ≈ Ping) for standard wired connections. Using Wi-Fi or LTE may require increasing SRT latency to compensate for excessive packet loss. We recommend the SRT Latency for standard Internet connection = 300-500 ms.

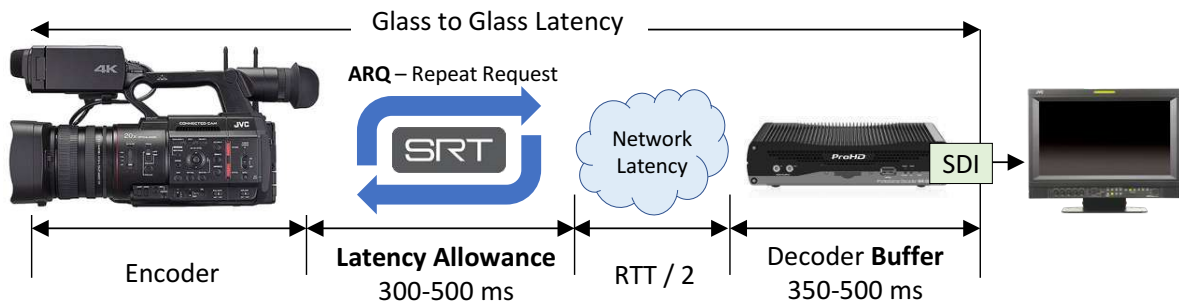

## Multi-camera streams synchronization.

Connected CAM camcorders are equipped with the NTP clock which can be synchronized with NTP servers, e.g. *time.google.com*. When this option is selected, the TC is switched to UTC and embedded in the SEI of the H.264 stream. Each decoder, synced to the same NTP server, reads the TC, buffers streams, and outputs in sync, with the specified time offset, e.g. "UTC + 1.5 sec".

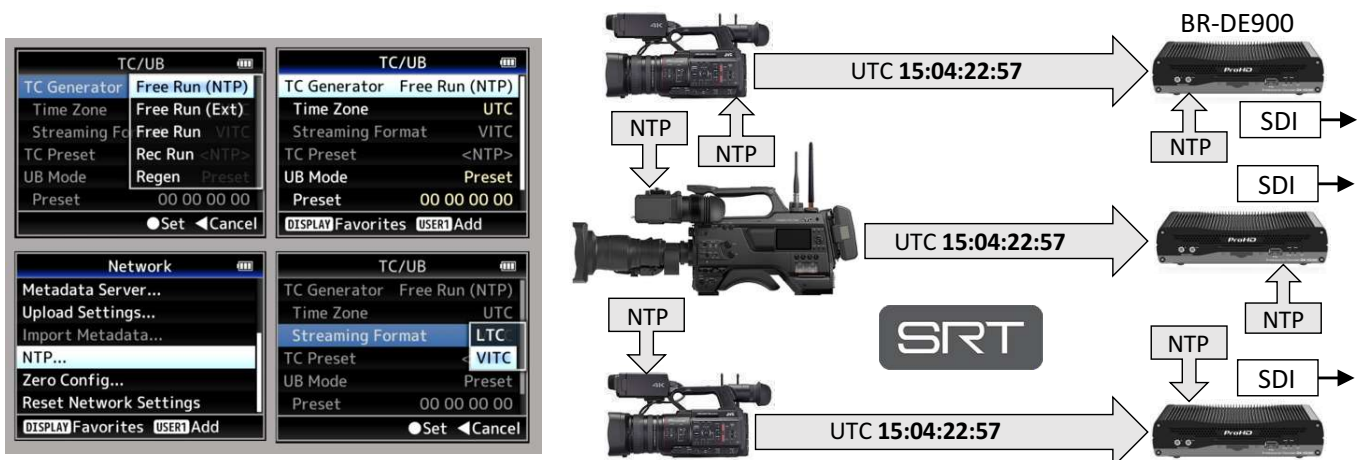



## Remote Control – RCU.

JVC camcorders feature full remote control over IP / Internet. *User name* and *password* should be preset prior to using this function by accessing **Menu** → **Network** → **Web** menu screen. Default control Port = 80 but it can be changed since some ISPs may block this port. Pressing the **Status** button and navigation to the "Connection Setup" screen shows the IP address of the camera which should be entered in the Chrome browser for GUI access.



## Firewall and NAT configuration.

In most situations, both camera and decoder (video switcher) are connected to the Internet via local area network(s) behind Firewall / NAT. On location, the "SRT Caller" stream will pass thru the local firewall as an outgoing connection. At the studio ("SRT Listener"), ports need to be forwarded to the local IP address of the decoder/switcher.

Remote Control (RCU) access may be blocked by a location firewall. Forwarding port or setting up the VPN may be needed to access the camera(s) on location.

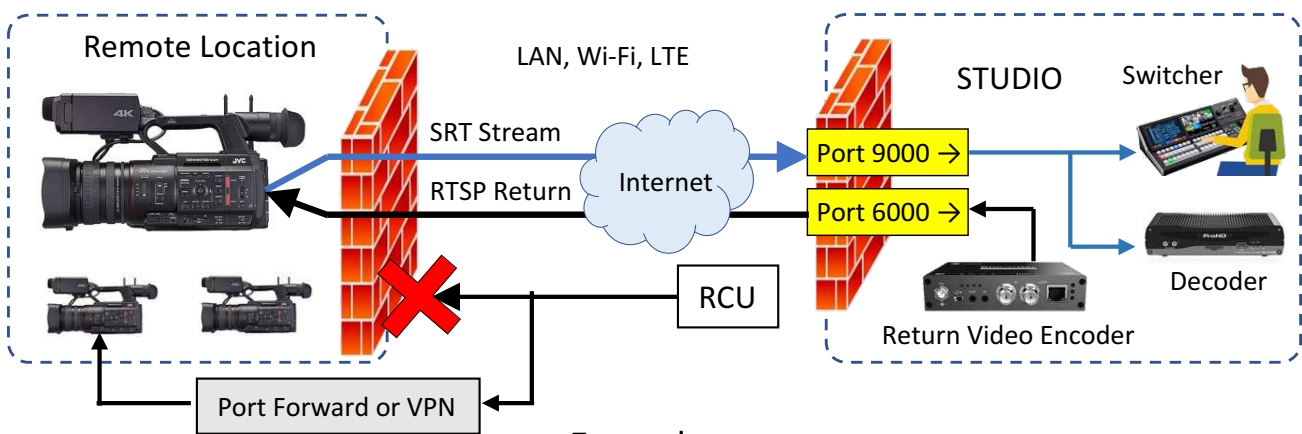

Example:

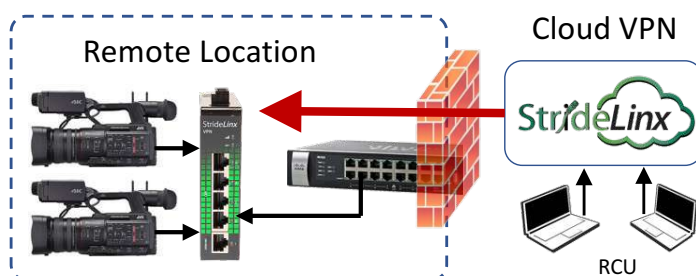

Placing the [StrideLinx SE-SL3001 VPN Router](#) between cameras and the local router creates the "outgoing VPN" and allows to access cameras and other devices behind the firewall directly from the browser from anywhere via the Internet. [Peplink](#) offers hardware-based VPN solutions and cloud services as well.

Remote Location ← REMI → STUDIO

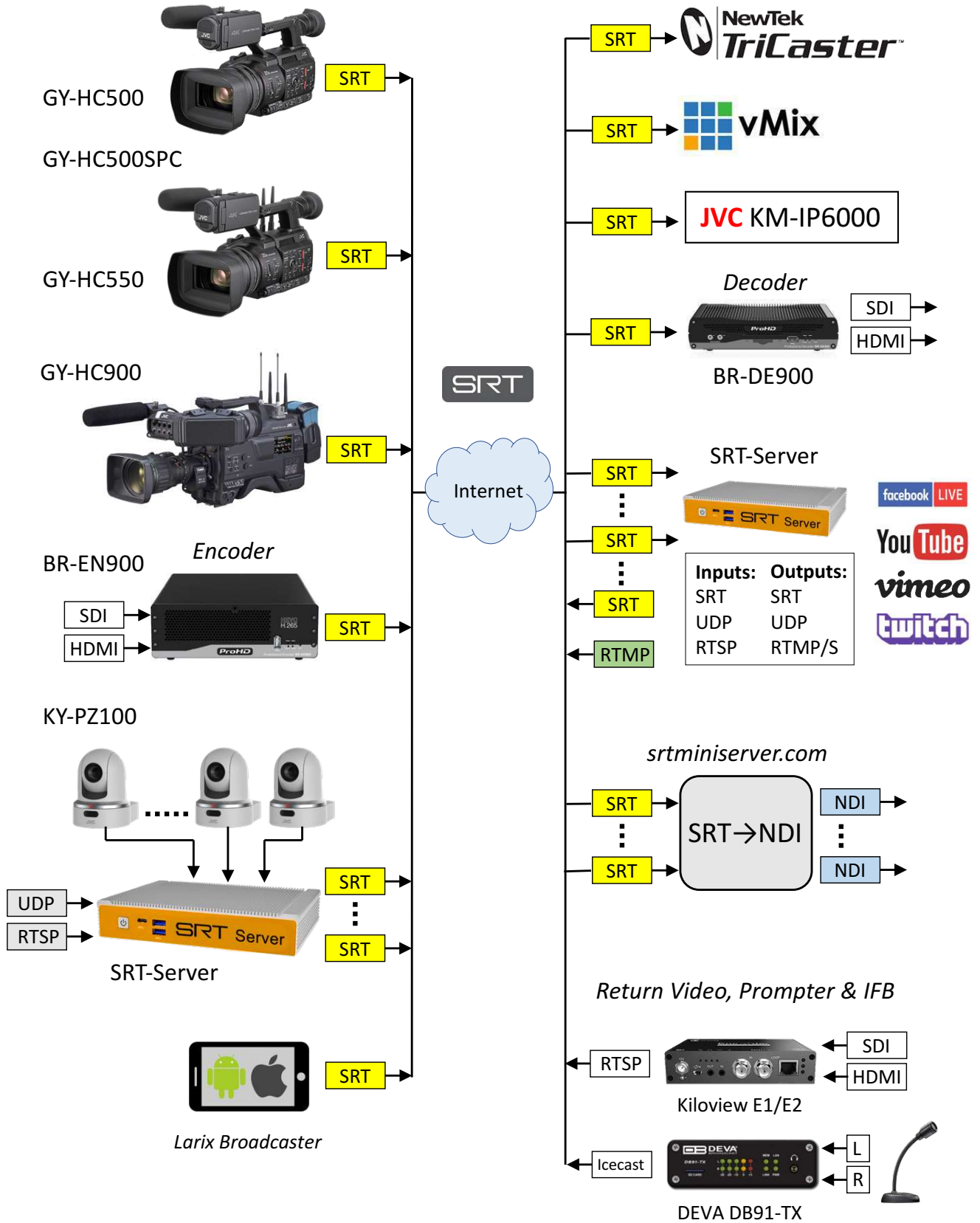

# REMI Example:

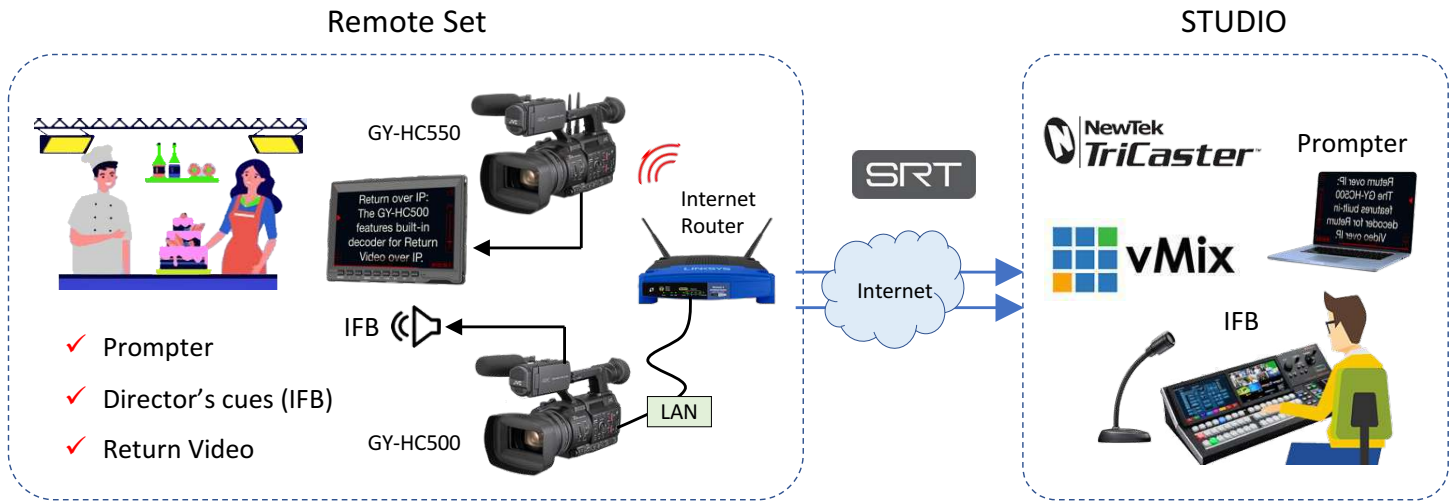

Model	Description
<b>On Location</b>	
GY-HC500/550	1" CMOS camcorder with built-in SRT encoder
GY-HC900	2/3" B4 lens camcorder with built-in SRT encoder
Prompter Monitor	SDI Monitor for Prompter or Return Video
IFB Headset or Speaker	3.5mm stereo headset or power speaker (BT TX/RX)
<b>Studio</b>	
vMix / Tricaster / KM-IP6000	Video Switcher with SRT inputs
Prompter	Prompter software PC/Mac
Kiloview E2	Prompter encoder with HDMI input
DEVA DB91-TX	IFB (Return Audio) encoder

### Recording Formats and IP functions – limitations:

The GY-HC500/500SPC/550 camcorders feature UHD (4K) recording to SDXC cards and optional SSD drive (ProRes codec). All models support 120p HD recording (slow motion) and simultaneous recording to two SDXC cards with different bitrates/resolutions. Optional KA-EN200 plug-in module enables HEVC streaming up to 10-bit 4:2:2 1080 60p. However, these functions require extra CPU utilization which may limit the camera's ability to stream live video and/or receive return video over IP.

Setting recording to "HD" enables all streaming functions, resolutions, and bitrates.

Menu → System → Record Set → Record Format → System = HD.

	RCU over IP	Streaming Video	Return Video over IP
4K Recording to SSD (ProRes)	Yes	No	
4K Recording to SDXC			
HD Recording to SSD (ProRes)			
HD Recording to SDXC		Yes	Yes
HD+Web Recording to SDXC		No	
High-Speed Recording (120p)			
HEVC Streaming with KA-EN200		Yes	No

