



FS-900

ProHD Fiber Remote System



ProHD



FS-900 Featuring

- ✓ Cost-efficient three-camera studio configuration with single base station
- ✓ Supports 1080 50/60p 3G-SDI camera feed and returns
- ✓ Camera adapter design allows to use VF-HP790 or generic SDI monitors as studio VF
- ✓ HDMI / SDI feeds for high-quality HD teleprompters
- ✓ Gigabit Ethernet for Video-over-IP and web-based RCU
- ✓ Dual redundant power supplies

The FS-900 is a new camera mounted Fiber optic system designed for JVC's GY-HM890 ProHD camcorder. Built exclusively for JVC by MultiDyne® Video & Fiber-Optic Systems, the system supports 3G-SDI 1080p/60 camera feeds and returns, and takes advantage of the camera's built-in streaming engine for video-over-IP functionality

FS-900 — Fiber Remote System

The JVC ProHD fiber systems include a camera adapter (for the GY-HM890) and base station, with either RTS intercom or CC (Clear-Com) compatibility.



An integrated fiber based system for a variety of remote applications

Ideal for a range of ENG and EFP applications the FS-900 system replaces multiple, bulky cables with durable lightweight fiber cable for robust two-way communication between cameras and control systems

The FS-900, a 3-camera fiber optic base station, provides camera control, 3G-SDI 1080p/60 camera feeds and returns and power for up to three ProHD cameras. The FS-900 camera module connects directly to the back of the GY-HM890 camcorder via 68-pin interface—no external cables required—for full studio functionality. It transports multiple bi-directional 3G-SDI signals as well as control, audio, sync, and intercom between the camera and the FS-900 Base Station.

Up to three cameras are supported by the Base Station, and its redundant power supplies provide up to 150 watts for each camera, as well as prompters and talent monitors. Its three-in-one configuration provides a more cost efficient solution than other multi-camera solutions previously offered by JVC and other manufacturers. The fiber optic multiplexing system replaces the bulky multicore cables with durable, lightweight fiber cable.

With built-in gigabit Ethernet, the lightweight, 2 RU Base Station also allows video-over-IP, control and advanced configuration. The high quality 1080p video signals are ideal for webcasts, virtual sets, and image magnification (I-MAG) applications. The system integrates easily with any studio, mobile truck, or portable flypack, and connects directly with a facility's switcher, router, intercom, and house sync systems.

FS-900 – Three-camera Fiber System

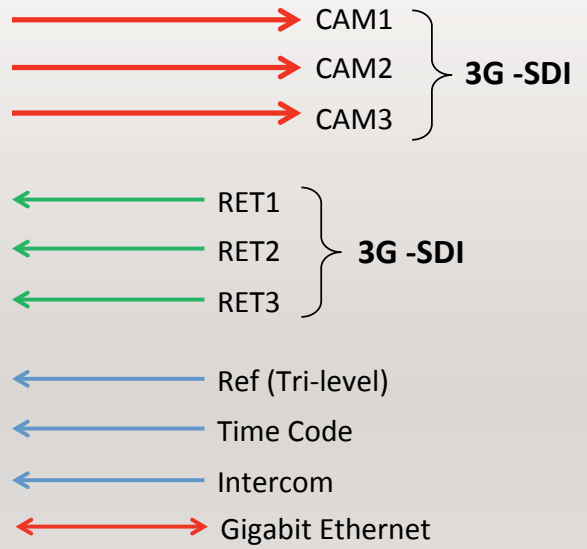

- 1080 60p 3G-SDI camera feeds and returns
- Gigabit Ethernet
- 150W per camera for prompter, talent monitor, clock etc.
- Optional Multi-viewer and SDI-over-IP cards



FS-900 base station rear panel

Integrated Simplicity, the RS-900 and GY-HM890



GY-HM890

ProHD Shoulder Camera

There's never been a more versatile high quality professional camera than JVC's GY-HM890U—an advanced 3-CMOS camera that delivers pristine HD images to solid state memory and streams via Wi-Fi or a plug-in LTE modem. It features a removable 20x Fujinon auto-focus lens, 4 channels of audio, dual memory card recording at up to 50 Mbps, an external HD-SDI pool feed input, and a full complement of fiber and multicore studio options. It's the most feature-rich HD camera JVC has ever offered, and now, the availability of the FS-900 Fiber Remote System makes it truly an essential component of any modern broadcast company.



*GY-HM890 full studio configuration

FS-900 ProHD Fiber Remote System

Full Control through Extended Base Station Connections

Designed for total integration with existing systems, the FS-900 base station offers complete connections for video (two HD/SDI outputs with return SDI and VBS connections for analog signals), audio (RTS TW intercom module) and sync/control functions (bi-level or tri-level sync, prompter input, time code, GPI signals and remote camera control input), providing unprecedented control for a range of field applications.



FS-900 Rear Panel Configuration

FS-900 Specifications

Digital Video, Camera to Base	
Number of Channels	1 Per Camera
Interface	SMPTE ST259, ST292, ST424
Data Rate	270Mbps, 1.5Gbps, 3Gbps
Input/Output Level	800mVp-p
Input/Output Impedance	75 Ohms
Number of Outputs at Base	2 Per Camera

Digital Video, Base to Camera	
Number of Channels	3 Per Camera
Interface	SMPTE ST259, ST292, ST424, HDMI**
Data Rate	270Mbps, 1.5Gbps, 3Gbps
Input/Output Level	800mVp-p
Input/Output Impedance	75 Ohms
Connectors	BNC, HDMI***

**HDMI camera output is only available on Return channel #3 for prompter use, only SMPTE compatible resolutions are supported. All inputs at base unit are SDI.
***Return channel #3 output has both a BNC and an HDMI connector, all other outputs are BNC only.

Video, Genlock	
Number of Inputs	1 + Loop Output
Type	Analog Black Burst, Tri-Level
Impedance	75 Ohms
Connector, Camera Unit	Internal
Connector, Base Unit	BNC (x2)

Audio, Camera to Base	
Type	Embedded in Camera's SDI video
Number of Channels	Max supported by camera

Audio, Base to Camera	
Number of Channels	2
Type	Balanced Analog Line-Level, mono
Level	+4dBu nominal, +24dBu max.
Connector, Camera Unit	DB9
Connector, Base Unit	DB25

Intercom	
Number of Channels	2
Interface	2-Wire or 4-Wire
Compatibility	RTS, Clear-Com
Connector, Camera Unit	XLR-5
Headset MIC Type	Dynamic
Headset MIC Impedance	200 Ohms nominal
Connector, Base Unit	DB25

RCP Camera Control (Remote)	
Number of Channels	1 Per Camera
Connector, Camera Unit	Internal
Connector, Base Unit	6 pin Mini-DIN (x3)

Ethernet	
Number of Channels	1 Per Camera
Data Rate	10/100/1000 Base-T
Connector, Camera Unit	RJ45 Cat5e
Connector, Base Unit	RJ45 Cat5e (x3)

Timecode	
Number, Base to Camera	1 per Camera
Number, Camera to Base	1, from Camera # 1 only
Inputs	Unbalanced, 15Vp-p max
Outputs	Unbalanced, 3Vp-p
Connector, Camera Unit	Internal
Connector, Base Unit	BNC

Tally/GPIO	
Number, Base to Camera	3 per Camera (Red, Green, Spare)
Number, Camera to Base	1 Per Camera
Inputs	Short to GND or TTL Low to Activate
Outputs	Relay Contact Closure (30V, 2A max)
Connector, Camera Unit	DB15
Connector, Base Unit	DB25

Electro-Optical	
Operating Wavelengths	1471-1611nm
Tx Laser Output Power	0dBm (Class 1 Laser)
Receiver Sensitivity	-20dBm
Fiber Compatibility	Single-mode
Optical Connector Types	opticalCON DUO, SMPTE 304M

Mechanical/Environmental	
Dimensions (HxWxD)	
Camera Unit	8.2" x 6.7" x 4.2"
Base Unit	3.5" x 19" x 16" (2RU)
Environmental	0 to 50°C, 0 to 95% RH, non-condensing.
Power Input, Base	IEC320, Universal Input, 90-250VAC, 50-60Hz
Power Input, Camera	Remote Power
Hybrid Fiber Connector	Local Power
Battery Mount	((Anton Bauer or (Optional) V-Mount))

Notes:

- All pictures in this brochure are simulated.
- All product and company names mentioned are trademarks or registered trademarks of their respective owners.
- All values for weights and dimensions are approximate.
- Specifications are subject to change.

JVCKENWOOD

JVCKENWOOD USA Corporation

1700 Valley Road

Wayne, NJ 07470

pro.jvc.com