

JVC
PROFESSIONAL

D-ILA™ PROJECTOR
DLA-M15



Slim, compact, and lightweight — JVC's new DLA-M15 D-ILA™ projector is the perfect replacement for the massive 3-tube CRT projectors that were once the only choice for anyone who needed large-screen projection images in bright lighting conditions. With the DLA-M15, you can project brilliant, high-resolution, big-screen S-XGA images that truly rival images produced by conventional CRT projectors. With 1500 ANSI lumens of brightness, a single lens design that eliminates complicated alignments, and an adjustable shift lens that lets you stack projectors for even greater brightness output, the DLA-M15 is the ideal solution for today's projection requirements.



Incredibly clear projection images – even in brightly-lit rooms

Single-Lens Solution for Big-Screen Projection Systems

— Breakthrough D-ILA™ Technology is Bringing the Era of CRT Projectors to an End —

D-ILA™ Device for Next-Generation Image Reproduction

Utilizing a high-density reflective LCD with a homeotropic structure in which the LCD elements are aligned vertically, the D-ILA™ (Direct Drive Image Light Amplifier) device produces extra-bright, high-resolution, high-contrast images ideal for big-screen projection applications.

Adjustable 1.5:1 Lens

The DLA-M15's adjustable shift lens makes it very easy to adjust screen position. The projection lens can be manually offset between 30% and 55% in the vertical direction, so you can quickly obtain an optimal projection image even when using two DLA-M15s in a stacked configuration. Complicated adjustments are not required and the DLA-M15's superior image reproduction capability makes it ideal for use in large conference rooms, halls, and media centers.



Stack-Mounted Image Photo

Adjustable Lens vs. Screen Position

Normal Projection (0% shifted)

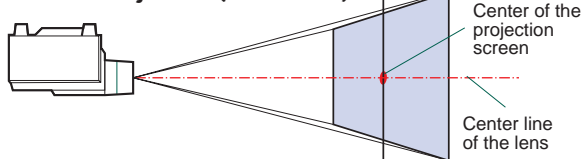

Offset Projection (30% - 55% shifted)

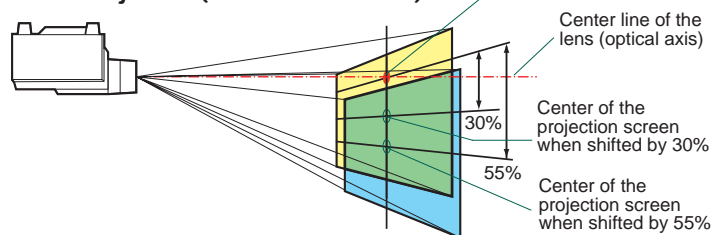

* Screen shift percentage is based on screen height = 100

Workstation-Quality True S-XGA Resolution

The D-ILA™ projector can project extra-high resolution images of up to 1,365 x 1,024 pixels. That means it can easily handle even the super-sharp clarity of an S-XGA (1,280 x 1,024 pixels) image without the scaling or loss of quality that normally occurs when projecting the high-resolution computer graphics and CAD images produced by today's cutting-edge workstations and laboratories. The small text, characters, icons and cursors typical of a computer display are clearly legible even at the corners of the projected image.

Ultra-High Brightness — 1500 ANSI Lumens

Incorporating a high-power 420 W Xenon lamp, the DLA-M15 boasts a brightness level of an incredible 1500 ANSI lumens. Together with the equally impressive contrast ratio of 350:1, this ensures that the images you see on the big screen are as clear and bright as they would be on a small monitor — even under bright lighting

conditions. The higher contrast brings out the tiniest details even in dark portions of the picture — something not possible with conventional LCD projectors — while the Xenon lamp assures “true” color and clarity. The result is “realistic” color reproduction that's comparable to high-end CRT projectors.

Innovative Technologies for Superior Image Quality

The **Adaptive DPC (Digital Pixel Conversion) circuitry** optimizes picture quality regardless of the input signal resolution to ensure smooth, clear images. Variable scanning frequency capability with horizontal scanning frequencies ranging from 15 kHz to 82 kHz assures compatibility with a wide range of source signals. The **10-bit Digital Gamma Correction** circuitry facilitates accurate gray scale and color reproduction. Even the intricately colored images created by graphics workstations can be clearly reproduced and displayed on the screen thanks to improved color

tracking while “real” black reproduction capability assures crisp blacks for cleaner, sharper, more detailed images.

Easy Maintenance & User Friendly Design

The DLA-M15 is ready to start operation within two minutes of switching the power on. Even with a twin-stacked configuration, initial setup procedures and complicated adjustments are minimal. The DLA-M15's single lens construction eliminates the need to adjust registration and the user-replaceable lamp design simplifies maintenance.

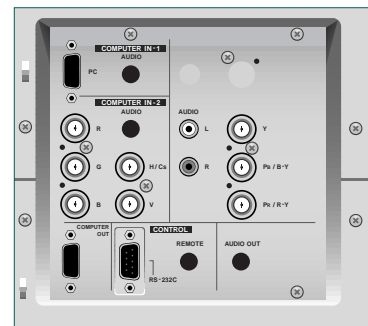

Full signal input capability

An Optimum Solution for Replacing CRT Projectors

With a lens that has the same projection ratio as that used in many CRT projectors, the DLA-M15 can be installed in practically same position, providing an easy replacement option. And thanks to the lens shift capability, you won't have to reposition the projection screen either.



EVENTS

Eye-catching demonstrations can be performed at trade shows and other events. The crisp, high-contrast images on the large screen will be sure to catch the audience's attention.



Maximize the impact of your presentations with a display your audience won't soon forget. When connected to a computer, the D-ILA™ projector can turn an ordinary presentation into a stunning multimedia experience. Its extra-bright, high-contrast images are clearly visible to everyone in the audience even in a relatively bright room such as a conference room.

BUSINESS

DLA-M15 Throw Distance vs. Screen Width

(Offset projection angle: 42.5%)

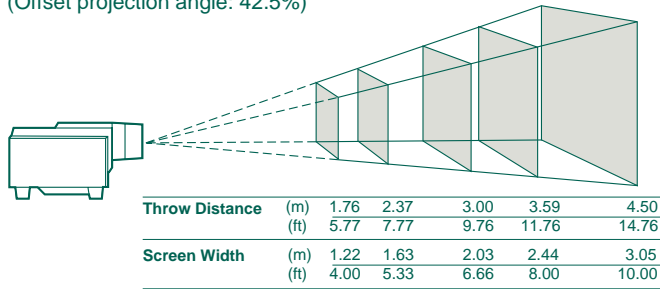

Other Features

- Wired remote control (optional) (Shown below)
- Auto-alignment function for automatic adjustment of tracking, phase and position
- Up-down/left-right inversion
- Selectable color temperature (High/Mid/Low)
- Selectable background color (when no signal is input)
- On-screen menu (6-language selectable)
- Resizing function for full-screen projection of XGA/S-VGA/VGA images
- 1000 hours of lamp life
- Lamp life "warning" indicator
- Lamp "sleep" function – in the absence of any signal for a preset time (10 min., 20 min., 30 min. or 60 min. selectable), the lamp is automatically shut off for safety and power saving



SPECIFICATIONS

Image Device:	3 D-ILA™ (0.9 inches diagonal)
Projection Lens:	1.5 : 1 (Throw distance : Screen width) 30% – 55% Manual shift with fine adjustment of screen size
Brightness:	1,500 ANSI lumens
Resolution:	1,365 x 1,024 pixels (full coverage of S-XGA (1,280 x 1,024) graphics (S-XGA, XGA, S-VGA, VGA))
Contrast Ratio:	More than 350 : 1
Color Reproduction:	16.7 million colors
Scan Frequency:	
Horizontal:	15 – 82 kHz
Vertical:	50 – 78 Hz
Input:	Analog RGB x 2 (D-Sub (female) x 1, R/G/B/H/V x 1) Component x 1 (Y/R-Y/B-Y, Y/ P _b / P _r for HDTV)
Output:	
PC Monitor:	D-sub (female)
Audio:	Stereo
Throw Distance:	1.8 m – 4.5 m (5.8 ft – 14.9 ft)
Screen Size:	1,524 mm – 3,810 mm (60" – 150") (diagonally)
Lamp:	420 watts, Xenon
Audio:	Built-in stereo speakers (1 W + 1 W stereo)
Power Requirements:	200 – 240 V, 50/60 Hz AC
Power Consumption:	660 W
Dimensions(WxHxD):	425 x 246 x 339 mm (16.73" x 9.68" x 13.35") excluding lens
Weight:	15.4 kg (33.9 lbs)
Provided Accessories:	AC cable, Wireless (infrared) remote control, PC connection cable (D-sub 15-pin male – D-sub 15-pin male), Adapter for Macintosh, AV cable, Audio cable, BNC-RCA adapter, Lens cap, Operation manual, Battery for remote control unit x 2

Dimensions

Unit: mm (inches)

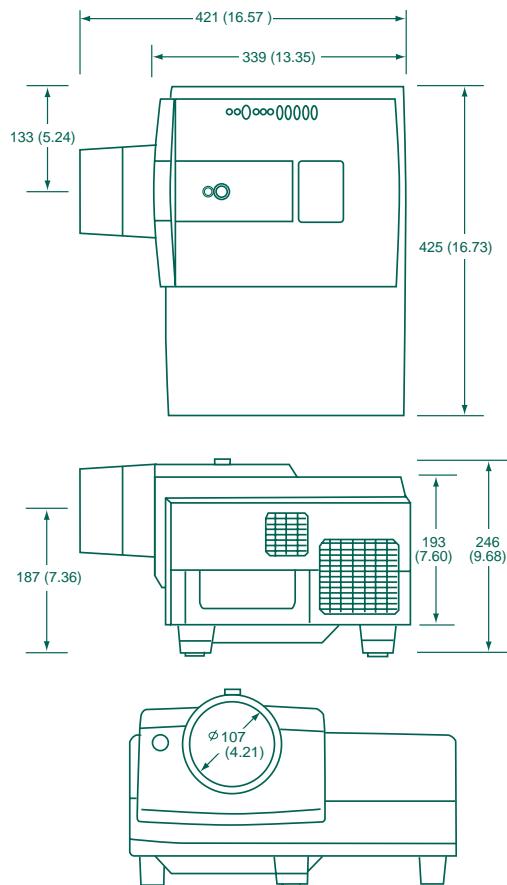

D-ILA is a trademark of Victor Company of Japan, Limited.

Design and specifications subject to change without notice.

Copyright © 1999, Victor Company of Japan, Limited (JVC). All Rights Reserved.

JVC

DISTRIBUTED BY